

Model: Orca v6

Document Number: LF-UM-001

Document Version: 1.6



**LUNGFISH**

# LUNGFISH ORCA v6 REBREATHER

## USER MANUAL



Lungfish Dive Systems Ltd, New Cambridge House, Litlington, SG8 0SS. U.K.  
Tel: +44 (0) 1763 294019 Email: [info@divelungfish.com](mailto:info@divelungfish.com) Web: [www.lungfishdivesystems.com](http://www.lungfishdivesystems.com)

## Do Not Dive Without Instruction

**Use:** The Orca v6 Closed-circuit Rebreather is classified as CAT III PPE under regulation (EU) 2016/425 and is designed to protect against drowning. The use of such PPE requires training to operate it correctly. The lack of training, or not applying that training can lead to drowning or death by other means.

This document contains information about the correct operation of a Lungfish Orca v6 electronically controlled rebreather.

### **It is IN NO WAY a substitute for taking a training course.**

Contact Lungfish Dive Systems Ltd or your training agency for details of instructors in your area.

## Do Not Dive Solo

Diving alone greatly magnifies the severity of any problem you may encounter as, if incapacitated, you are unlikely to be rescued.

This problem is magnified in rebreather diving, the silence, stealth and range afforded by the equipment further reduce your prospect of recovery.

Likewise, if separated from your buddy or team follow the guidance of your training and if impossible to locate them during a pre-arranged time, terminate the dive.

## Know Your Limits

This document covers the operation of the Orca v6 rebreather only and does not contain guidelines for the procedures necessary to successfully perform any dive. Dive within the envelope of your qualification and ability. Never dive without a bailout option (See 5.8).

Understand that special equipment, overhead environments and decompression dives require special training.

Ensure you have had appropriate medical examination and you are fit to dive in the intended circumstances.

## Warnings, Cautions and Notes

Pay special attention to information provided in Warnings, Cautions, and Notes as follows:

---

**Warning:** Tells you that a procedure or situation that may result in serious injury or death if a point is not adhered to.



---

**Caution:** Tells you that any situation or technique that will result in potential damage to the product or render the product unsafe if instructions are not followed correctly.



---

**Note:** This wording is used to stress that the information may have safety implications if attention is not paid to this instruction.

### Copyright Notice

This documentation contains information which is subject to copyright. No part of it may be photocopied, duplicated, translated or recorded on data media without prior consent from Lungfish Dive Systems Ltd. All rights reserved.

Copyright © 2022 Lungfish Dive Systems Ltd.

### Disclaimer

Lungfish Dive Systems Ltd gives no implicit guarantees regarding standard qualities or suitability for a certain application.

Lungfish Dive Systems Ltd reserves the right to make changes to this documentation at any time.

This version of the manual is for CE and UKCA countries.

### Certification

The Lungfish Dive Systems Ltd, Orca v6 Rebreather has been UK certified, Module B Type approval and the ongoing conformity (Module C2 or D), i.e. SGS UK Ltd, Approval Body 0120 at the following address - Rossmore Business Park, Ellesmere Port, Cheshire CH65 3EN. and EU Certified, Module B Type approval and the ongoing conformity (Module C2 or D), by SGS Fimko OY Notified Body 0598 at the following address - SGS Fimko Oy, Takomotie 8, FI-00380 Helsinki. It is classified as PPE under the EU Directive 2016/425. It has been tested in accordance with EN 14143:2013. Respiratory equipment – Self-contained re-breathing diving apparatus.

Declaration of conformity: <https://www.lungfishdivesystems.com/copyorcav6>

#### Warning:



- **Swapping or altering any parts on this unit may invalidate the CE certification and the warranty. Any unauthorized modifications may compromise the safety, performance, and compliance of the product.**

## Document History

The following table shows the version history of this document:

Version	Date	Details
1.0	12 <sup>th</sup> July 2022	First release.
1.1	26 <sup>th</sup> September 2022	Second release.
1.2	10 <sup>th</sup> August 2023	Third release: BCD care details
1.3	15 <sup>th</sup> December 2023	Breathing loop revision
1.4	28 <sup>th</sup> February 2024	Certification Review
1.5	22 <sup>nd</sup> April 2024	Certification Review
1.6	24 <sup>th</sup> April 2024	Certification Review

# Table of Contents

---

- LUNGFISH ORCA v6 REBREATHER..... 1
  - Do Not Dive Without Instruction ..... 2
  - Do Not Dive Solo ..... 2
  - Know Your Limits..... 2
  - Document History..... 3
- 1. Introduction..... 6
  - 1.1. Overview of Orca v6 main components – front view..... 7
  - 1.2. Overview of Orca v6 main components – back view..... 8
  - 1.3. Options for your Orca v6 ..... 9
- 2. Main Components.....11
  - 2.1. Breathing Loop .....11
  - 2.2. Counterlungs .....14
  - 2.3. Oxygen Supply System .....17
  - 2.4. Diluent Supply System.....21
  - 2.5. Scrubber Unit .....24
  - 2.6. Electronics Module.....27
  - 2.7. BCD and Harness .....36
- 3. Assembling the Rebreather .....38
  - 3.1. BCD & Harness .....38
  - 3.2. Installation of the Diluent System .....38
  - 3.3. Installation of O<sub>2</sub> System.....39
  - 3.4. Oxygen Cylinder.....40
  - 3.5. Diluent Cylinder .....41
  - 3.6. Securing the Cylinders .....41
  - 3.7. Inhale Counterlung Installation .....42
  - 3.8. Exhale Counterlung Installation.....43
  - 3.9. Breathing Loop .....44
  - 3.10. Scrubber .....46
  - 3.11. Preparing, Fitting and Removing the Electronics .....52
- 4. Pre-Dive Preparation.....65
  - 4.1. Pressure Checks.....65
  - 4.2. Pneumatics Check .....66
  - 4.3. Counterlung Sizing .....67
  - 4.4. Weights .....68

5.	Diving the Orca v6.....	69
5.1.	PO <sub>2</sub> monitoring and control.....	69
5.2.	Dive Preparation .....	75
5.3.	Entering the water.....	77
5.4.	Descending .....	77
5.5.	Buoyancy control .....	78
5.6.	Ascending .....	78
5.7.	Diluent Flush .....	79
5.8.	Bailout procedure.....	79
5.9.	Exiting the water.....	79
5.10.	System Alarm Messages.....	79
5.11.	Diving alert messages.....	87
5.12.	Breathing volume management .....	93
5.13.	Water in the rebreather .....	94
6.	Cleaning Post dive .....	98
6.1.	Cleaning and disinfection of the Orca v6 after diving.....	98
6.2.	Cleaning and disinfection of the BCD after diving.....	99
7.	Care, User Maintenance and Servicing .....	100
7.1.	Breathing Loop .....	100
7.2.	Maintenance of Counterlungs.....	102
7.3.	Maintenance of the Oxygen and Diluent Systems .....	103
7.4.	Care and maintenance of the Scrubber Canister.....	105
7.5.	Care and Maintenance of the Electronics Module .....	105
7.6.	BCD and Harness care .....	110
8.	Troubleshooting .....	112
8.1.	Notes on sensor faults .....	112
8.2.	Pressure checks .....	114
9.	Technical Specifications.....	115
9.1.	Limitations on use.....	115
9.2.	Health Effects .....	117
9.3.	BCD warning label.....	117
10.	Preparation Checklist .....	120

# 1. Introduction

---

The Lungfish Orca v6 ECR (Electronically Controlled Rebreather) is one of the most practical, robust and easy to use rebreather systems available. It contains multiple unique features to ensure your safety and comfort while diving. These include:

- Advanced and reliable electronics including world-leading CO<sub>2</sub> detection,
- High levels of redundancy,
- Easily adjustable counterlung capacity for a perfect fit to each diver and reduced risk of hypoxia.
- A user-friendly control system minimising interference with buoyancy.
- A highly visible display viewable from any angle.
- An ergonomic and easy to operate mouthpiece for an unobstructed view and minimised fatigue.
- Offboard monitoring and additional analogue outputs, offering compatibility with third party dive computers.

It is intended for any diving application where silence, endurance, freedom of movement, warmth, and minimised decompression are required, or simply just to enjoy diving without the bulk and weight of standard equipment or other rebreathers.

This document describes the main parts of the rebreather, how it should be assembled and maintained. It is not a definitive guide to rebreather diving and is no substitute for the appropriate training and experience.

As Personal Protective Equipment (PPE), before diving a rebreather it is essential that you receive specialist training. For details of Diver and Instructor training contact Lungfish Dive Systems Ltd (LDS) or see [www.lungfishdivesystems.com](http://www.lungfishdivesystems.com).



---

**Warning: All gases used need to be in accordance with EN 12021.**



### 1.1. Overview of Orca v6 main components – front view

Dimensions: Height 65cm,  
Width 40cm, Depth 25cm.

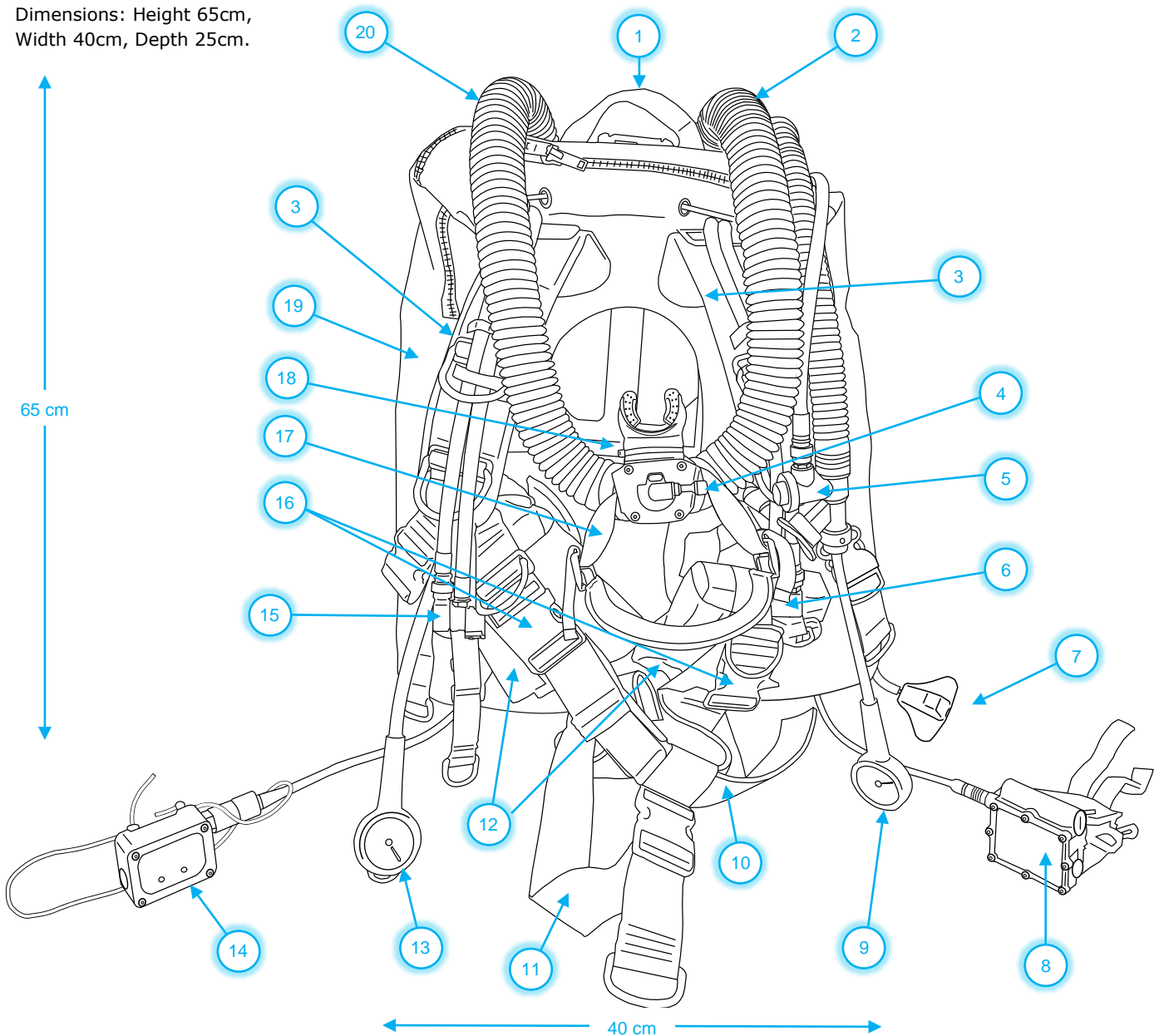

1	Carry Handle	11	Crotch Strap
2	Exhale Hose	12	Weight Pouches (optional)
3	Shoulder Straps	13	Oxygen Pressure Gauge
4	Dive/Surface Valve (DSV) Lever	14	Primary wrist display (Handset)
5	BCD power inflator	15	Oxygen Manual Add Valve (MAV)
6	Diluent Manual Add Valve (MAV)	16	Weight pouch release buckles (Optional)
7	Counterlung OPDV Toggle	17	Mouthpiece Retaining Strap
8	Secondary (decompression) display (optional)	18	Mouthpiece
9	Diluent Pressure Gauge	19	Wing Buoyancy Compensator Device (BCD)
10	Waist belt	20	Inhale hose

## 1.2. Overview of Orca v6 main components – back view

Dimensions: Height 65cm,  
Width 40cm, Depth 25cm.

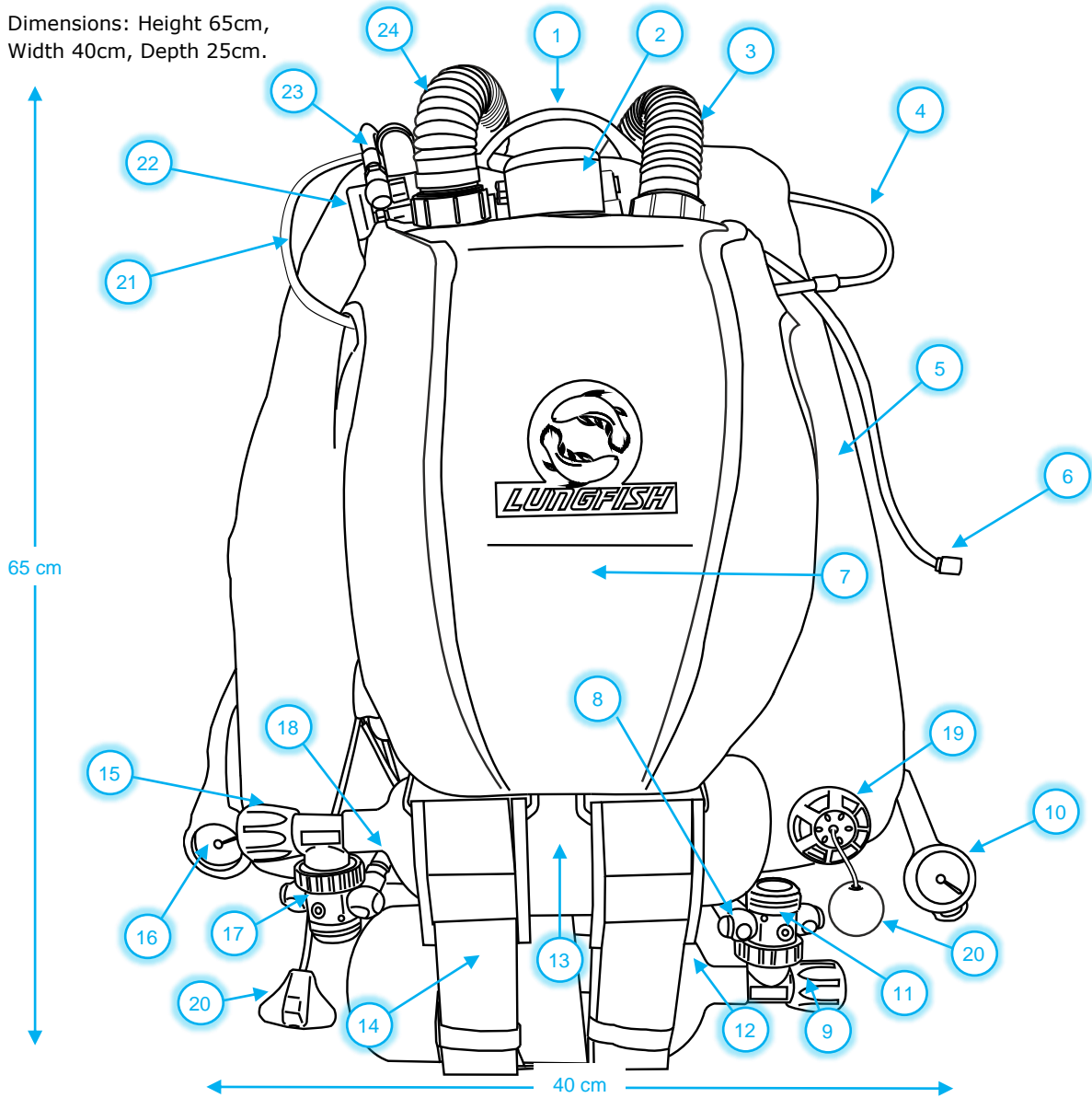

1	Carry handle	13	Diluent Cylinder
2	Automatic Diluent Valve (ADV)	14	Cylinder Straps
3	Inhale Hose	15	Diluent Cylinder Valve
4	Handset Cable	16	Diluent Pressure Gauge
5	Wing Buoyancy Compensator Device (BCD)	17	Diluent First Stage
6	Drysuit Inflator Hose (optional)	18	Diluent feed to Manifold
7	Outer Casing containing Scrubber, Counterlungs & Electronics Head	19	BCD Overpressure Dump Valve (OPDV) and toggle
8	Oxygen feed to Solenoid	20	Counterlung OPDV Toggle
9	Oxygen Cylinder Valve	21	Secondary Display Cable
10	Oxygen Pressure Gauge	22	Diluent Manifold
11	Oxygen First Stage	23	BCD inflate/deflate hose
12	Oxygen Cylinder	24	Exhale Hose



### 1.3. Options for your Orca v6

LF 06000020 ORCA v6 (A0) comes supplied with an Electronics Head with a standard size handset (LF 06065020), no extra analogue output ports and no fourth Oxygen Sensor fitted. The Outer casing can be black/black (LF 06070091) or black/silver (LF 06070012). Pressure gauges are supplied as standard and can be either under arm - 58 cm (LF 06041031 - Diluent and LF 06040052 - Oxygen) or over shoulder - 100 cm (LF 06046271 - Diluent and LF 06040181 - Oxygen).

LF 06000030 ORCA v6 (A1) comes supplied with an Electronics Head with a standard size handset, one extra analogue output port and no fourth Oxygen Sensor fitted. The Outer casing can be black/black (LF 06070091) or black/silver (LF 06070012). Pressure gauges are supplied as standard and can be either under arm - 58 cm (LF 06041031 - Diluent and LF 06040052 - Oxygen) or over shoulder - 100 cm (LF 06046271 - Diluent and LF 06040181 - Oxygen).

LF 06000040 ORCA v6 (A2) comes supplied with an Electronics Head with a large size handset (LF 06065510), two extra analogue output ports and a fourth Oxygen Sensor fitted. The Outer casing can be black/black (LF 06070091) or black/silver (LF 06070012). Pressure gauges are supplied as standard and can be either under arm - 58 cm (LF 06041031 - Diluent and LF 06040052 - Oxygen) or over shoulder - 100 cm (LF 06046271 - Diluent and LF 06040181 - Oxygen).

#### 1.3.1. Electronics Options (CO<sub>2</sub> sensor is standard)

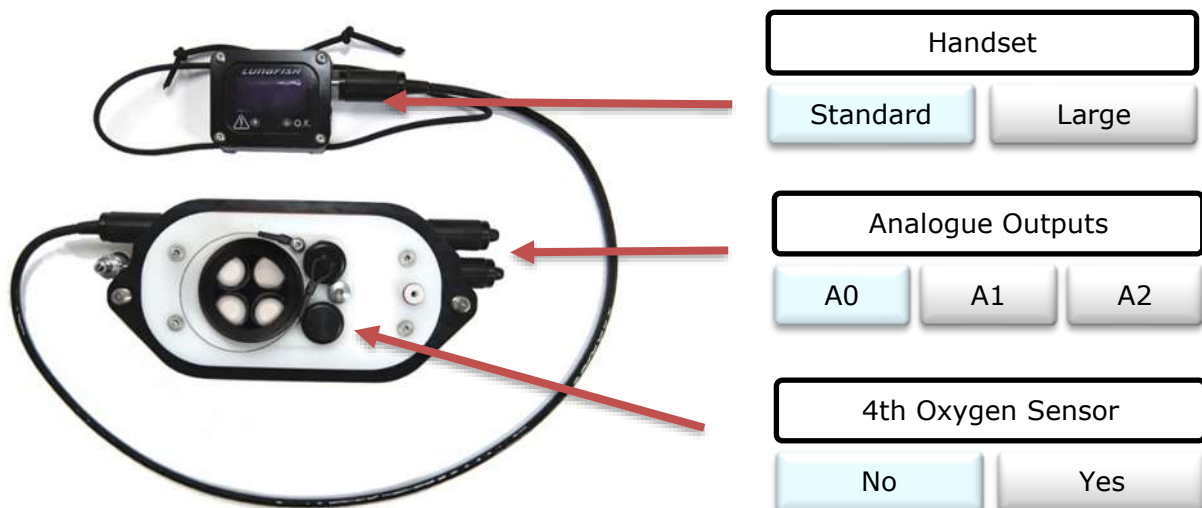

### 1.3.2. Hardware Options



Outer Casing

Black

Silver

Pressure Gauges

Under Arm

Over Shoulder

## 2. Main Components

---

The Orca v6 rebreather consists of the following subsystems:

- Breathing Loop
- Counterlungs
- Oxygen Supply System
- Diluent Supply System
- Scrubber Unit
- Electronics Module
- Harness, Backplate, Outer casing and Wing BCD

These are described individually below.

### 2.1. Breathing Loop

The standard breathing loop, with an ergonomic, comfortable mouthpiece and exceptionally low breathing resistance and dead space.



The standard breathing loop consists of the mouthpiece and the Inhale and Exhale Hoses and the Mouthpiece Retaining Strap (see image left). Fresh gas is supplied to the user through the Inhale hose on the right (with a black connector), while exhaled gas is returned to the rebreather for CO<sub>2</sub> removal and re-oxygenation through the Exhale Hose on the left (with a red connector). This conforms to the "Rich-Right, Lean-Left" rule applied throughout the whole rebreather.

#### 2.1.1. Mouthpiece

The main body of the mouthpiece (see image below, with Breathing Hoses connected) contains the following parts:

- A Dive/Surface Valve (DSV), allowing the user to be ON and OFF the breathing loop, by operating the DSV Lever (see below).
- A standard Mouthpiece Bite to retain the assembly in the user's mouth.
- A mounting plate to hold a Mouthpiece Retaining Strap, to reduce the risk of accidental loss of the mouthpiece underwater (not attached below for clarity).
- The connections to attach the breathing hoses and the valves that create directional flow around the circuit.

The overall assembly is an ergonomic design, carefully shaped to achieve the following aims:

- Very low “dead space” volume to reduce rebreathing of CO<sub>2</sub>
- To direct the hoses away from the face, for a clear view and streamlined profile.
- To reduce jaw fatigue and allow easy turning of the head, giving improved comfort during the dive.
- To minimise breathing resistance as far as possible.
- To allow easy one-handed operation of the Dive/Surface Valve.
- To avoid the risk of accidentally going ON or OFF the loop
- To enable total elimination of water from the mouthpiece when replacing in the mouth underwater.

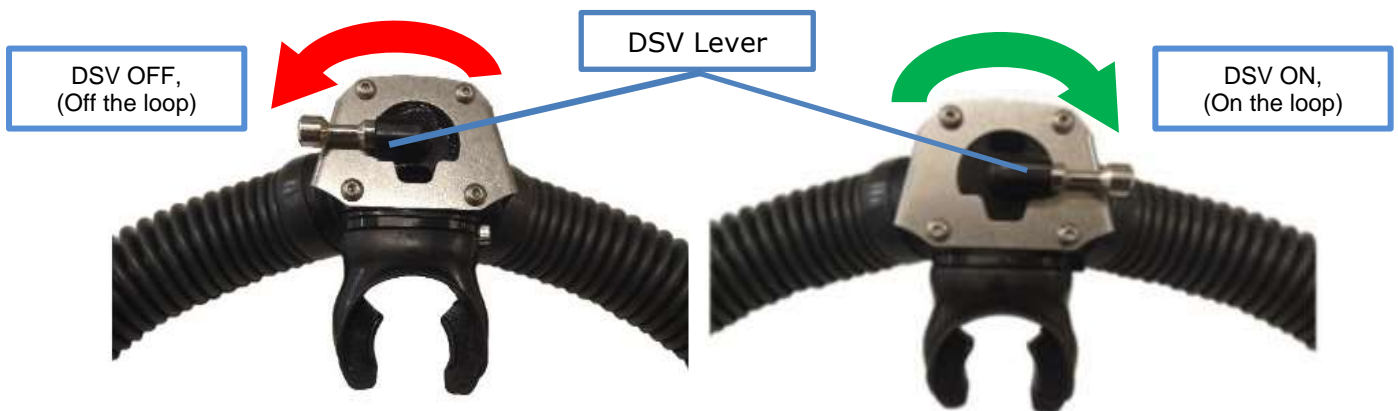

**The Dive/Surface Valve (DSV)** allows the user to switch between breathing from the rebreather and breathing from the atmosphere on the surface, or to close the rebreather if swapping breathing systems underwater.

Turning the lever to the right (remember “rich on the right”) aligns it with the Inhale hose (same principle) and puts the diver ON the breathing loop, allowing the user to breathe from the rebreather.

Turning the lever to the left (remember “lean on the left”) aligns it with the Exhale Hose and puts the diver OFF the breathing loop. In this position, the rebreather is sealed and the mouthpiece is connected to a small hole on top of the DSV, enabling the user to breathe atmospheric air if at the surface, or purge out water if going back on the loop underwater.

The turning action is easily performed one-handed and the lever must always be turned all the way in either direction, to avoid the machine being partially ON or OFF.

**The Mouthpiece Bite** is the rubber element that fits in the diver’s mouth. The Mouthpiece Bite supplied with the Orca v6 is large. This is because the passage of gas in and out of the Unit must not be obstructed.

**The Mounting Plate and Mouthpiece Retaining Strap** are supplied to offer the diver an extra level of comfort and safety, by further reducing the effects of jaw fatigue and reducing the risk of the mouthpiece becoming dislodged underwater.



The strap has adjustable fittings, enabling easy donning and adjustment for comfort underwater.

**Connections to the Breathing Hoses** are made by a simple push-fit mechanism with a locking cord. This system enables straightforward removal of the hoses for inspection or replacement of the mushroom valves (see image below). It also allows the hoses to be rotated underwater to adjust the angle of the mouthpiece, if necessary for improving comfort underwater.

This means of attachment also reduces the width of the assembly, to reduce jaw fatigue and allow unrestricted head movement.

### 2.1.2. Breathing Hoses

The mouthpiece is connected to two breathing hose assemblies, one exhale and one inhale hose, to form the breathing loop. Each hose assembly contains the hose, the fittings to connect the hose to the mouthpiece and the counterlungs, and the one-way valves that provide directional flow. These are positioned at the very end of the hoses to provide the absolute minimum of dead-space within the mouthpiece, reducing CO<sub>2</sub> exposure as much as possible.

Exhale Hoses (below left) terminate in a red fitting, and inhale hoses (below right) terminate in a black fitting. These correspond to red and black fittings on the exhale and inhale counterlungs respectively and are shaped so that they cannot be cross-connected.



Exhale Hose.  
Above: Mouthpiece end showing the mushroom valve stem.  
Below: Exhale Counterlung connection.



Inhale Hose.  
Above: Mouthpiece end showing the mushroom valve.  
Below: Inhale Counterlung



The Exhale Hose (red) is connected to the left of the mouthpiece (from the diver's perspective), and the Inhale (black) hose is connected to the right. The loop is supplied assembled: the hoses only need to be removed from the Mouthpiece for inspection or maintenance of the mushroom valves. This is detailed under Maintenance below.

**The One-Way Valves** are mushroom valves like the Exhale valve on an open-circuit SCUBA second stage. They are positioned inside the breathing hose connectors, close to the mouthpiece end to reduce dead space.

Although the valves are hidden from view, the diver should check they are operating correctly. This process is detailed in the Assembly section below. A further feature of the hoses is that their “twist” can be adjusted to vary the angle of the mouthpiece in the mouth. The angle of twist can be verified by looking at the seams along their edges. Both sides should be the same.

Twisting the fittings once plugged into the rebreather (at the counterlung end, not the mouthpiece) will adjust the angle of the mouthpiece during assembly. If necessary, the hoses can also be rotated at the mouthpiece end to make further adjustments underwater. This process is detailed in the Assembly section below.

## 2.2. Counterlungs

The Orca v6 rebreather has two counterlungs – an Inhale and Exhale, one before and one after the scrubber. Having two lungs divides the scrubbing between the counterlung parts of the breathing cycle. This arrangement doubles the time the exhaled gas is exposed to the scrubbing material while reducing the breathing resistance.



The “adjustable volume” feature of the counterlungs is performed by an adjustment to the casing that contains them – see section on Counterlung Sizing for details.

The shape of the counterlungs - and the positioning of their various fittings and Velcro panels make it intuitive and easy to assemble the machine correctly.

The counterlungs are made from a durable multilaminate material with a smooth lining. This, and the fact that the main connectors are completely flush with the inside, makes cleaning and drying the lungs extremely easy.

### 2.2.1. Exhale Counterlung

The Exhale Counterlung is narrow at the top (where the breathing hose connects) and wide at the bottom. This improves breathing comfort and acts as a water trap, should water get into the system. It has one threaded hose connector (see image below), a red scrubber connector with two O-ring seals (which aligns with the left port of the scrubber) and an Overpressure Dump Valve (OPDV) to eject excess gas or any liquids. The threaded connector has a ridge inside to ensure only the Exhale Hose may be connected, and to prevent the Inhale hose being connected by mistake.

With the scrubber connector uppermost, the Exhale Counterlung should sit in the left-hand side of the Unit (when laid flat), with the Velcro panels attached to the corresponding Velcro panels on the left of the rebreather, with the exhale hose connector in the left-most hole in the top of the casing and the OPDV facing downwards and left.



1	Scrubber connector	5	Velcro panel
2	Breathing hose connector	6	Groove for scrubber connector locking clip
3	OPDV Cap and Toggle and Yellow Locking Cord	7	Scrubber Connector Lower O-ring
4	OPDV One Way Valve	8	Scrubber Connector Upper O-ring

The OPDVs are based on those found on many BCDs. They differ as one-way valves are installed inside them. This prevents any water entering the rebreather if they are opened while there is a negative internal pressure relative to the outside. The valves may be visually examined by removing the screw-down lid.

While diving, water accumulates in the counterlungs over time due to condensation from the user’s breath. This is more noticeable in cold water. Any saltwater accidentally admitted to the Unit (e.g., by dislodgement of the mouthpiece) will also be trapped in the

Exhale Counterlung. Build-up of any of these liquids during a dive may be apparent by gurgling or sloshing noises in the hoses. Any liquid detected can and should be expelled by adding gas while exhaling and opening the OPDV, to avoid the risk of it entering the scrubber material.

The positioning of the OPDV allows easy draining of liquids from the counterlungs when the diver is in the prone position with the rebreather on the back. Rolling 45° down to the left while maintaining a normal, slightly head-up pitch puts the OPDV at the lowest point of the machine.

Any water in the Unit will drain to that position and the diver can then exhale fully, pull the Exhale Counterlung OPDV toggle, and simultaneously, manually inject diluent. This will cause the liquid to be expelled, with no immediate change to the diver's buoyancy.

### 2.2.2. Inhale Counterlung

The Inhale Counterlung is wide at the top where the Inhale Hose and ADV connect through the casing, and narrow at the bottom (see image below). This again improves breathing comfort, and the position of the scrubber connector allows this lung to serve as a water trap too. Check this after each dive. The counterlung also connects to the scrubber with a locking connector, and has a threaded connector for the inhale hose, and a push-fit connector for the ADV. The scrubber connector has cross-holes to aid removal of condensation from the base of the scrubber.

With the scrubber connector uppermost, the Inhale Counterlung should sit in the right-hand side of the Unit (when laid flat on its Harness), attached to the corresponding Velcro panels on the right, with the hose connector in the right-most hole in the top of the casing and the ADV connector in the central hole.

---

**Note: Water will accumulate in the Inhale counterlung over time. This should be clean, fresh water condensed from water vapour generated by the user and the scrubbing reaction. Salt or alkaline water in the Inhale counterlung indicates a leak or a scrubber flood.**

---





1	Diluent valve connector	4	Velcro panel
2	Scrubber Connector	5	Groove for Scrubber Connector Locking Clip, with cross-holes
3	Breathing hose connector	6	Scrubber Connector Lower O-ring

## 2.3. Oxygen Supply System

### 2.3.1. Oxygen Cylinder

The Lungfish 2-litre steel cylinder for oxygen has been designed for a good combination of adequate gas supply (especially if high pressure oxygen is not available), low weight (easy to transport), convenient size (fitting easily across the user’s back), and high density (reducing the need to carry lead).



The standard cylinder valve has an EN 144-3 M26 x 2 Oxygen fitting to avoid misconnection. (To simplify logistics in areas with different oxygen standards, an ISO 12209:2013 G5/8 200 bar cylinder valve is also available, with corresponding fittings for the first stage regulators – this option is not certified for CE and UKCA EN 14143:2013)

### 2.3.2. Oxygen First Stage & Downstream Components

The oxygen first stage pressure reducer takes gas stored at high pressure in the cylinder and supplies it to the solenoid and manual add valve at a constant pressure above ambient. Note that this is a lower pressure than is typically used in SCUBA systems, and that this first stage is not designed for open-circuit breathing and has not been tested to EN 250:2014 or other open circuit standards.

---

**Warning:**  **The oxygen 1<sup>st</sup> stage pressure reducer is not designed for open circuit breathing and has not been tested to EN 250:2014 or other standards for this purpose. Do not connect open-circuit demand valves to this regulator.**

---

Make sure to only connect the oxygen first stage to cylinders that are oxygen clean and contain oxygen. To reduce the risk of cross-connection with other gases, Lungfish-supplied oxygen valves have a green handle, and the oxygen system is supplied with the standard EN 144-3 M26 X 2 oxygen connection.

The oxygen supply system is supplied with the components shown in the image below.

---

**Warning:**  **Only use hoses that meet EN 250:2014 certification standards with this product. The use of non-certified hoses may compromise safety and performance.**

---

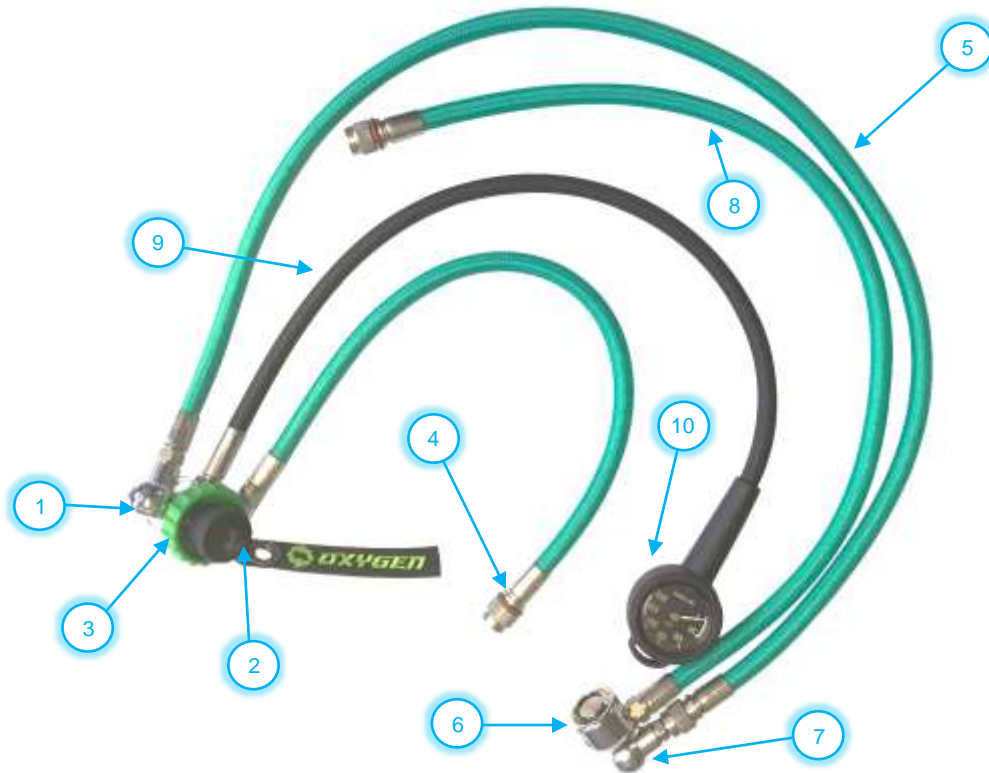

1	First stage regulator with swivels	6	Manual Add Valve (MAV).
2	Dust Cap with Velcro label.	7	Elbow with quick disconnect.
3	Overpressure valve with 3/8 UNF port.	8	MAV return hose. Note the locking O-ring (red).
4	Low Pressure (LP) hose to solenoid. Note the locking O-ring.	9	High Pressure hose. Standard length, long hose optional.
5	LP hose to MAV.	10	Pressure gauge.

To prevent the hoses becoming accidentally disconnected, an O-ring is placed at the end of the quick disconnect hoses. Once connected, the O-ring is rolled forwards over the ridge to sit just behind the knurled slider on the QD. This prevents it being slid back accidentally.

Move O-ring here for locked position

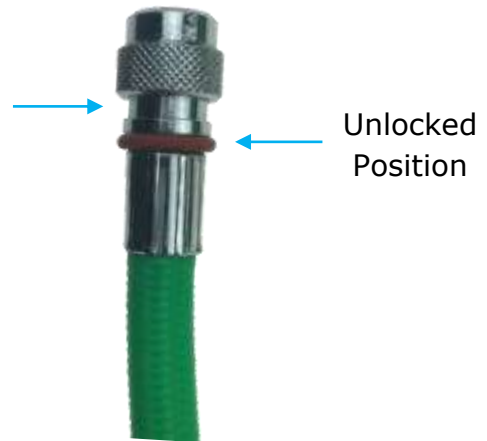

The Solenoid Hose and MAV return hose have the same fittings, for the sake of simplicity. It is however highly unlikely for them to be cross connected. If somehow the hoses were mis-connected during assembly, the solenoid would not work with the manual hose attached, which would be revealed in the prebreathe before the dive. Connecting the solenoid hose to the Manual Add Valve port on the scrubber would result in an instant, and hopefully obvious, free flow.

### 2.3.2.1. Manual Add Valves

The Manual Add Valve (right) enables the user to manually add oxygen or diluent to the rebreather loop. The design combines versatility, ease of operation, protection against inadvertent operation due to its recessed button, and ease of cleaning, giving longevity even when used in a harsh environment.



Identical Manual Add Valves are used for Oxygen and Diluent.

## 2.4. Diluent Supply System

### 2.4.1. Diluent Cylinder

As with the oxygen system, the Orca v6 rebreathers are available with a 2-litre diluent cylinder. This is supplied with an ISO 12209:2013 G5/8 200 bar valve.



### 2.4.2. Diluent First Stage & Downstream Components

The diluent first stage pressure reducer takes gas stored at high pressure in the cylinder and supplies it to the automatic diluent valve and manual add valve at a constant pressure above ambient. Note that this is a lower pressure than is typically used in SCUBA systems, and that this first stage is not designed for open-circuit breathing and has not been tested to EN 250:2014 or other open circuit standards.

---

**Warning:** The diluent 1<sup>st</sup> stage pressure reducer is not designed for open circuit breathing and has not been tested to EN 250:2014 or other standards for this purpose. Do not connect open-circuit demand valves to this regulator.

---



Make sure to connect the diluent first stage to cylinders containing an appropriate diluent for your dive. To reduce the risk of cross-connection with other gases, i.e. the oxygen supply, Lungfish supplied valves have a black valve handle, and the diluent system is supplied with the standard ISO 12209:2013 G5/8 connection.

The diluent supply system is supplied with the components in the image below.

Hose elbows and manual add valves are structurally identical to the Oxygen system described above.

---

**Warning:** Only use hoses that meet EN 250:2014 certification standards with this product. The use of non-certified hoses may compromise safety and performance.

---



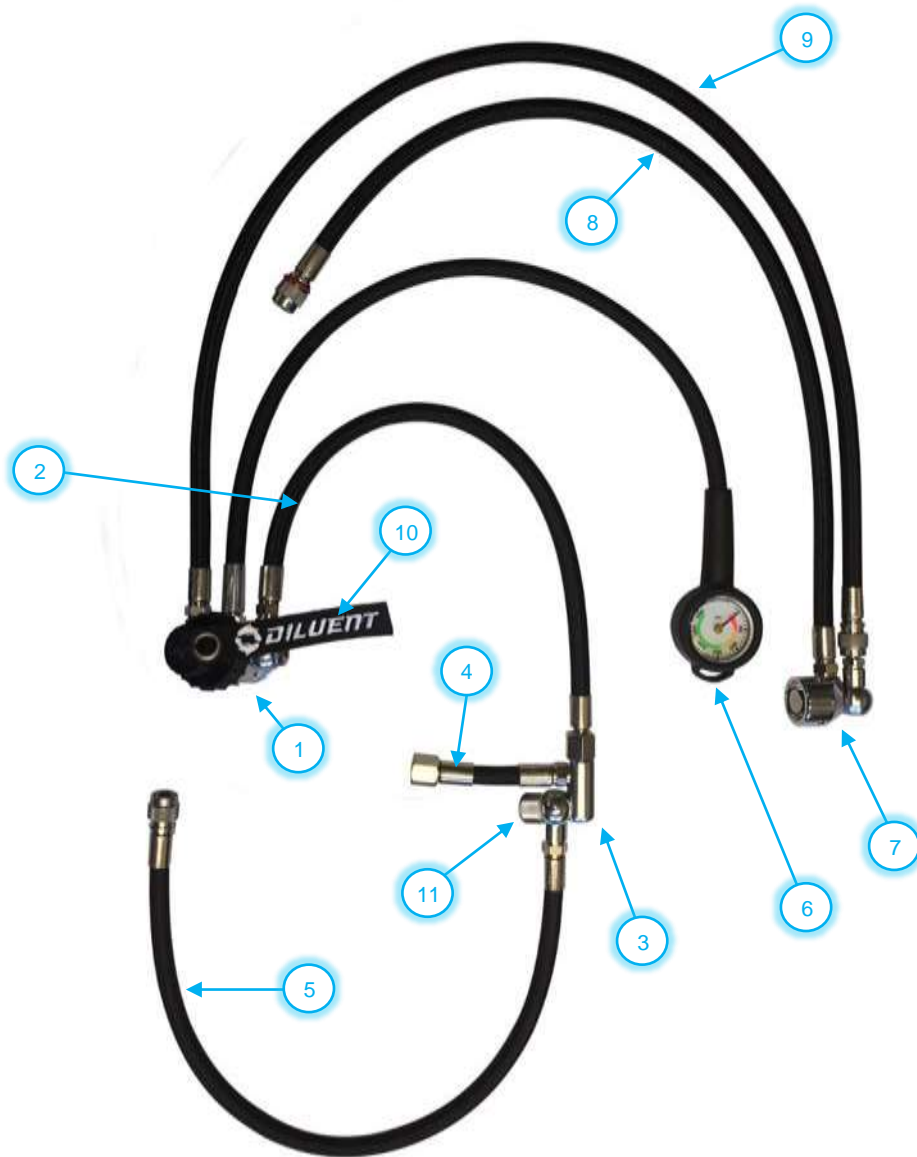

1	First Stage Regulator with Overpressure valve in 3/8 UNF port.	7	Manual Add Valve (MAV).
2	Hose to manifold.	8	MAV return hose (with locking O-ring).
3	Manifold.	9	MAV supply hose.
4	Short hose to ADV.	10	Dust Cap with Velcro label.
5	Hose to BCD.	11	Port for Drysuit hose.
6	Pressure gauge (Standard length, long hose optional).		

To prevent the MAV return hose becoming disconnected an O-ring is placed in the position shown above in the oxygen system section.

### 2.4.2.1. Manual Add Valves



The Manual Add Valve enables the user to manually add Oxygen or Diluent to the rebreather loop. The design combines versatility, ease of operation, protection against accidental operation due to the recessed button, and ease of cleaning, giving longevity even when used in a harsh environment.

Identical Manual Add Valves are used for Oxygen and Diluent.

### 2.4.2.2. Triple Connector

An optional triple connector (right) mounting for the MAV which allows the same hose to be used for the MAV and the BCD inflator. This offers several advantages, including:

- a reduction in the number of hoses required in the system.
- The ability for the diver to find a single object bearing both sets of controls rather than risking grabbing the wrong control.
- The ability to supply both the rebreather and the BCD from a bailout bottle if out of gas.

The Triple Connector can still be fitted as an option even if independent BCD and MAV hoses are supplied.



### 2.4.3. Automatic Diluent Valve (ADV)

In addition to the above, the Orca v6 diluent system feeds an Automatic Diluent Valve (ADV), see below, which is mounted on the top of the Unit behind the diver's head, connecting to the central port (left port of the Inhale Counterlung). This adds gas in response to suction if the counterlungs are empty.



The ADV is supplied tuned at the factory to an appropriate cracking pressure. Adjustments and all other servicing of this part should be performed by trained and competent persons.

## 2.5. Scrubber Unit

### 2.5.1. CO<sub>2</sub> Scrubber Canister

The Lungfish CO<sub>2</sub> scrubber (see below) is a moulded polymer canister built to contain 2.3 kgs of fine grade Sofnolime 797 1-2.5 mm (CO<sub>2</sub> absorbent). The canister is shaped to reduce breathing resistance, allow efficient use of the scrubber material and prevent build-up of moisture.

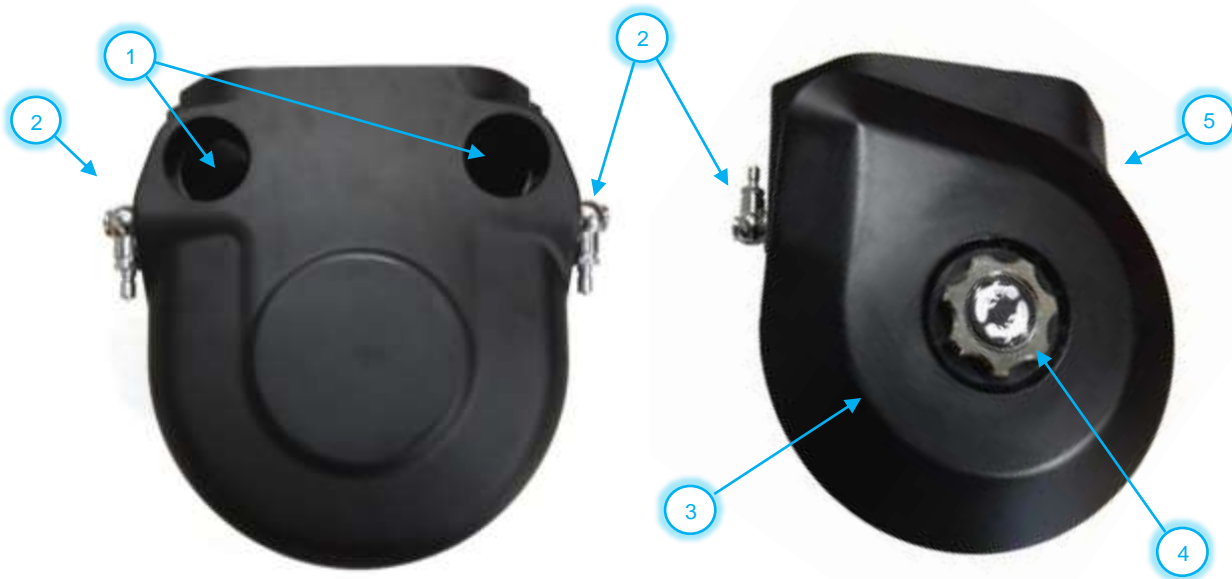

1	Counterlung Connector ports	4	Scrubber Lid Retaining Bolt
2	MAV QD Connectors	5	Scrubber Lid thumb tab
3	Scrubber Lid		

On the top face is a lid by which the scrubber canister may be refilled. It is sealed with a thick silicone O-ring and held in place with a Scrubber Lid Retaining Bolt. On one side is a thumb-tab enabling the lid to be lifted easily from the Unit once the bolt is removed.

On the sides of the canister are a pair of Manual Add connections. The gas feeding in from the MAV buttons are connected here. They allow gas to be injected into the space after the scrubber stack, just upstream of the sensors but not directly at them. This allows the sensors to be checked rapidly but avoids the risk of damaging them by direct blasts of compressed gas or liquid.

On the lower face are two ports where the canister joins to the two corresponding fittings on the counterlungs.





The inhale and exhale ports are differently shaped to prevent cross-connection. The Exhale Counterlung connection (inlet to the scrubber) is longer and has two O-rings. This also prevents the circuit bypassing the scrubber through the locking clip area. The Inhale connection (outlet providing fresh gas to the Inhale Counterlung) is shorter and has one O-ring, and perforations in the locking groove. These allow condensed water to escape into the Inhale Counterlung, keeping the scrubber material and sensors dry.

These fittings are secured in place with a white plastic locking clip indicated below with a green arrow.

At the front of the Scrubber is a recess for the Electronics Head.



Also visible is the port where oxygen is injected upstream of the scrubber by the solenoid (so that the gas is thoroughly mixed by the time it reaches the sensors), the outlet where cleaned gas exits the scrubber towards the sensors, the port where the cleaned gas enters the Inhale Counterlung, and the handle of the white Locking Clip that secures the counterlung ports in place.

### 2.5.2. Internal Scrubber Components

Removing the lid reveals the components used to hold the scrubber material in place. The first component is a 'Top Grid' (1) with a convenient handle allowing it to be lifted from the Unit.



Beneath this is a fabric mesh disk of absorbent/dust filter cloth (2), below this is a sponge (3) used to compress the scrubber material and hold it in place.

Removing the sponge shows the fill line around the inside of the circular canister, to which scrubber material is filled. The compression of the Scrubber Sponge in the resulting gap holds the material in place (See the Filling the Scrubber below).

Beneath where the scrubber material is filled a second fabric mesh disc (4), to prevent the passage of moisture or dust, and beneath this a 'Bottom Grid' (5). The Bottom Grid is fixed and sealed in place.



Below the bottom grid is the flow cone. This ensures an even flow of gas through the scrubber material and prevents any condensation formed in the bottom of the canister from draining back into the scrubber material.

### 2.5.3. Scrubber Materials and Duration

The canister is designed for the use of fine-grade Sofnolime type absorbents. The recommended absorbent is Sofnolime 797 1-2.5 mm. Absorbents are to be used according to manufacturer's instructions.

Do not use coarse grade materials. Typically, the coarser materials will lower resistance at a cost of less effective scrubbing. The Orca canister's shape is intended for the use of fine grade materials.

With Sofnolime 797 1-2.5 mm, the scrubber duration has been tested to 130 minutes under standard conditions (CO<sub>2</sub> injection 1.6 l/min, depth 40 m, water temperature 4 degrees C, ventilation 40 l/min)

CO<sub>2</sub> absorption efficiency is a function of many factors including the user size, work rate, breathing rate, gas mix, temperature and depth.

The Orca v6 Electronics Head is provided with a CO<sub>2</sub> monitor to warn of any breakthrough of the scrubber material.

---

**Warning:** Respond to any on-screen warnings and do not start a dive if the scrubber cannot achieve a CO<sub>2</sub> level of zero.



---

## 2.6. Electronics Module

### 2.6.1. Overview

The Orca v6 Electronics Module (see components below) measures and controls the oxygen level in the user's breathing mixture. It also shows the user the oxygen and carbon dioxide levels in their breathing mix, their depth and dive time and various other information, and alerts the user to unsafe breathing mixtures and other diving hazards. The Orca v6 Electronics Head records all measured parameters throughout the dive for later analysis. It monitors its own condition and will alert the user if it becomes damaged or disabled, as well as isolating any damaged parts and continuing to operate with reduced functionality.

The Electronics Module consists of two parts - the Head and Handset (see below). These are linked by a wet-mateable cable and sealed bulkhead connectors. The Head holds the gas sensors, pressure sensor, main processor, batteries, alarm and solenoid, in one rugged unit. The Handset holds an illuminated screen readable from a near flat angle, LED status indicators, and push buttons, which allow the user to turn the Unit on and off, view or select different parameters, and calibrate the Module on the surface.

The Module can optionally be equipped with an additional 4<sup>th</sup> oxygen sensor, and one or two optional offboard connectors for decompression computers, status indicators, umbilical links, or head-up displays. Also supplied is a USB Charge/Data Cable.



### 2.6.2. Electronics Head

The following features are visible on the Head (a full specification Unit is shown below with two analogue outputs):

- **Sensor Head:** This contains three oxygen sensors, and sensors for carbon dioxide, pressure and temperature.
- **Handset Cable Bulkhead:** this is positioned to allow the cable to run along the right arm. The cable can be turned around the arm before or after securing it on your wrist to prevent a potential snag hazard or otherwise secured.
- **Oxygen Inlet:** A quick release fitting. Connects the oxygen supply to the solenoid.
- **Oxygen Outlet:** Delivers oxygen upstream of the scrubber for better mixing.
- **Charge/Data Port:** Type B USB connector under a sealed cap.
- **Pressure Relief:** This is not a user serviceable part – leave in place.
- **Head Bolts:** For securing the Head to the scrubber.

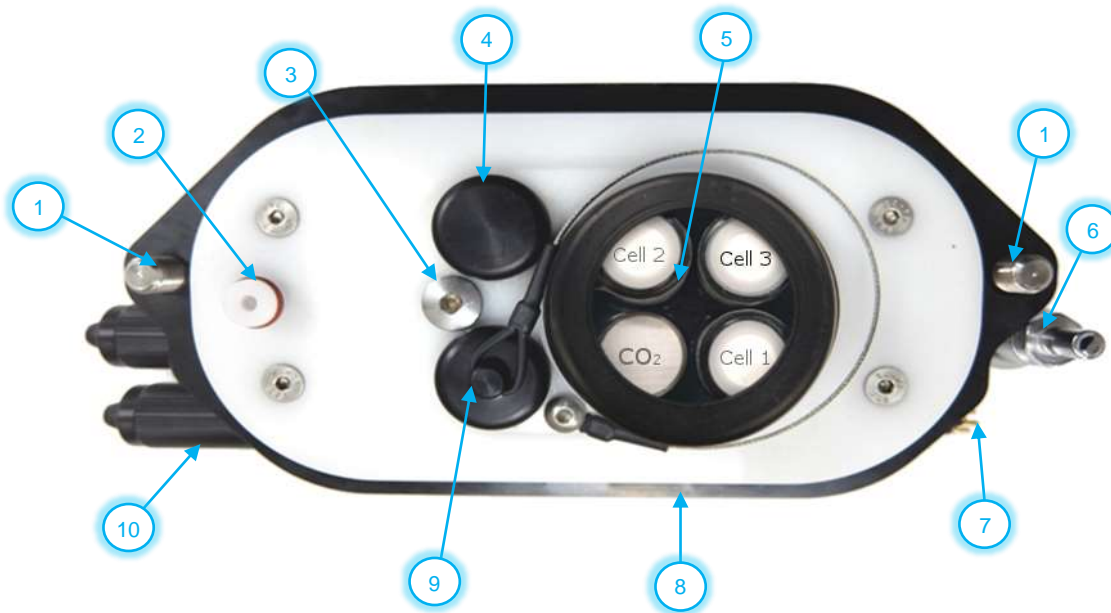

1	Head Bolts (2X).	6	Oxygen Inlet.
2	Oxygen Outlet.	7	Bulkhead Connector for Handset Cable
3	Pressure Relief.	8	Main O-ring.
4	4 <sup>th</sup> Oxygen Sensor Socket (blanked).	9	Charge/Data Port.
5	Sensor Head under the sensor cover.	10	Ports for external analogue output systems (with blank caps fitted).

The Sensor Head is specially designed to protect the sensors from any damage. The O-ring sealed guard reduces the likelihood of flooding from almost any angle (water is more likely to drain to the Counterlungs) while the sensors are further protected from water by a rubber seal about their bases, keeping their contacts dry. The oxygen sensors are user-changeable and are a specially designed type unique to LDS (Part Number LF0606031), being highly durable, accurate over a wide range, and compatible with this seal. They are however fuel cells, steadily consuming their electrodes, and are labelled with a "use by" date, and you should change the oxygen sensors every year. The expected life expectancy of the oxygen sensors is 12 months. Old or expired sensors may be recycled in any facility that can cope with batteries or may be sent back to LDS.

CO<sub>2</sub> and Depth Sensor are "solid state" and do not need to be replaced, although these are checked and calibrated during an annual service.

### 2.6.3. Analogue Output Ports

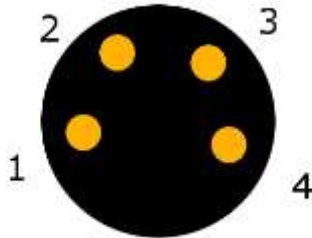

The analogue output ports terminate with four pins. Pin 1 is the Ground. Pin 2 has the reading from Oxygen Cell 2. Pin 3 has the reading from Oxygen Cell 3. Pin 4 has the reading from Oxygen Cell 1 (or Oxygen Cell 4 if fitted).

The Orca v6 A0 does not have an analogue output ports.

The Orca v6 A1 has 1 analogue output port.

The Orca v6 A2 has 2 analogue output ports.

The analogue output ports allow any dive computer or PO<sub>2</sub> monitor capable of reading galvanic oxygen cells to be connected, enabling live decompression calculations and a backup (secondary) means of monitoring loop PO<sub>2</sub>.

### 2.6.4. Handset

The handset is used to turn the system on and off and displays system status and dive information. The Orca Handset is unique in its clear display and extremely wide viewing angle, a huge advantage as it is usually possible not only to read your display without having to raise your hand to your face, but also to view your buddy's display and their status indicators at a distance.

Both the **Standard Handset (75 mm x 60 mm)** and the **Large Handset (88 mm x 65 mm)** versions have the following features:

- Buttons.
- Screen and Status LEDs.
- Bungee / Strap Wrist Attachment.
- Screen - Standard Handset 1.54", Large Handset 2.42". Both 128 pixel x 64 pixel.

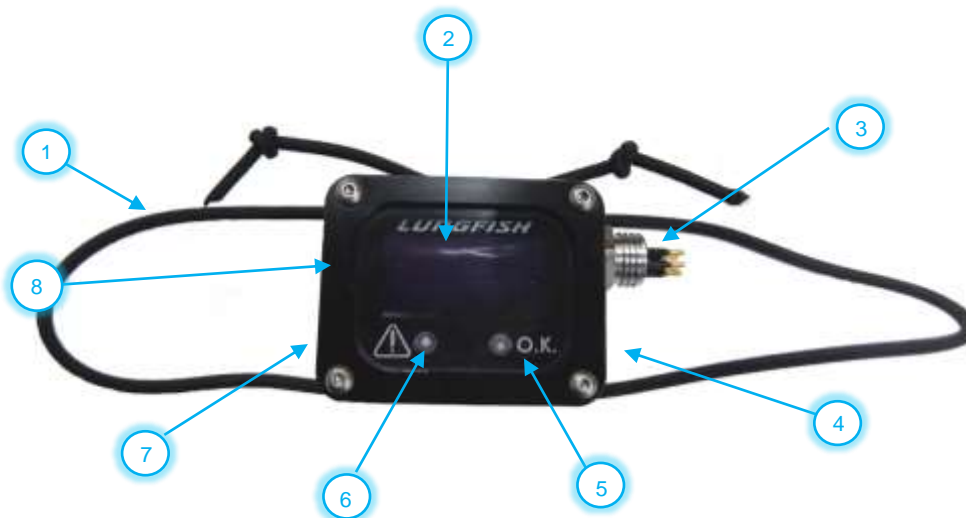

1	Bungee wrist attachment.	5	"OK" LED. Lights up green.
2	Screen area.	6	"Alert" LED. Lights up red.
3	Bulkhead Connector to Electronics Head.	7	Left button.
4	Right button.	8	Protective bezel.

### 2.6.5. Charging the Electronics Head

**Note:** **The Electronics Head is shipped in a charged state but should be charged immediately on arrival with the user.**



The Orca v6 is supplied with a Charge / Data Cable (see below) which connects to the Charge / Data Port at one end and a USB socket at the other. This can be used to charge the Electronics Head from any USB power source. This can be the USB port on a computer, or better, a higher powered (2 amp) mains or car charger (such as those used for electronic devices such as tablets). The Electronics Head contains its own Charge Controller. The same cable is used to download dive logs.

**Warning:** **ONLY use a 5V USB source and the correct cable to charge the machine, or short circuit and damage may result.**



**Note:** **Make sure to turn the system off during charging: otherwise, if left in the air, the solenoid will fire continuously, attempting to elevate the surrounding PO<sub>2</sub> to the Surface Setpoint! A Setpoint is a factory set or user programmable limit value for the desired partial pressure of oxygen.**

**This waste of power slows charging considerably - but will be accompanied by sounding of the PO<sub>2</sub> Low Alarm, so is unlikely to go unnoticed.**

There are two batteries in the Unit, which will charge simultaneously. One powers the solenoid valve, and one the rest of the system (processor and display).

**Warning:** If the Unit has been allowed to discharge below its working voltage, the display may still start and show a “communications failure” message. The solution is to charge the batteries.



You can check the level of the Orca v6’s batteries on the display.

To charge the Unit, remove the charge/data cap by pulling its lanyard (it pulls straight out). The charge/data cable is inserted into the USB port.



To remove the cable after charging, pull straight out.

### 2.6.6. Turning on the Electronics

The Left button on the handset is pressed to turn the system on. Use the left and right buttons to acknowledge the start-up checklists/reminders:

#### 2.6.6.1. Start-up checklist screens

Presses	Screen	Purpose
0	#1: Boot Screen	'Lungfish,' lights on for test. Lasts 9 seconds.
0	#2: Last Calibration	Last calibration and run time since last calibration.
1	#3: Cylinders full	Check O <sub>2</sub> and Diluent tanks are full. Y/N.
2	#4: Scrubber changed	Have you changed your scrubber material? Y/N.
3	#5: O <sub>2</sub> sensors	Have you checked your O <sub>2</sub> sensors? Check the sensor readings after the start-up checks if not already done.
4	#6: Batteries	Are the readings above 3.9v? Adequate charge? see the time remaining on this screen? Y/N.
5	# 7: Data Port	Is the cap on the data port in place and secure? Y/N
6	Default Screen	You have now reached the default screen.

**Note: This list is a memory aid only and no action is required. It is your responsibility as the diver if action is required.**

After the above checks you will be presented with the default screen, and you can check the Oxygen Sensor readings to verify if they displayed what you would anticipate.



- **Once turned on and at the Default Screen (Depth / Time / PO<sub>2</sub> / PCO<sub>2</sub>)**, seven right-button presses are required to have the option to turn off.
  - Repeated pressing of the right button will result in return to the default screen.
  - Alarms (audible, flashing red light and description of problem) are acknowledged by pressing the left button. The value of concern will continue flashing until the problem is resolved, but the buzzer will be disabled for a short while. It will resound if the problem persists.
- 
- **Note: Throughout this manual, "PO<sub>2</sub>" (Partial Pressure of Oxygen) and "PCO<sub>2</sub>" (Partial Pressure of Carbon Dioxide) is used. However, the sealed electronics displays may show "PPO<sub>2</sub>" and "PPCO<sub>2</sub>". This discrepancy does not affect functionality. Both terms refer to the same measurements.**
- 

### 2.6.7. Default Display, after start-up

The Default Screen shows the following information important to life support:



During correct operation underwater, the coloured light is green, and the text does not flash. On the surface, detached from the rest of the rebreather, a red light and a "PO<sub>2</sub> LOW" warning will appear.

- **DEPTH** is displayed in metres of seawater.  
The standard sensor is accurate between 0 and 130 M. An optional max depth alarm may be set by the user using the handset (pre-dive only) or via the PC link.
- **TIME** is displayed in minutes and seconds. An optional max time alarm may be set by the user using the handset (pre-dive only) or via the PC link.
- **PO<sub>2</sub>** is displayed in bar. The value shown is a consensus of the readings of the three sensors. Pressing the right button once shows the three individual sensor readings. In normal air, the oxygen level is 0.21. Connected to an oxygen supply, Unit itself will typically maintain an oxygen level between 0.6 and 1.3 bar.  
A "low" setpoint or if on the surface while on automatic mode) and 1.2 (once at sufficient depth while diving). The specified PO<sub>2</sub> alarm levels are between 0.5 and 1.55 bar.
- The system is set to alarm if the oxygen level is below 90% of the surface setpoint of 0.6, or above a safe limit of 1.55 bar.
- **PCO<sub>2</sub>** is displayed in KPa – 1 KPa is equivalent to 1% CO<sub>2</sub> at atmospheric pressure. The sensitivity of the monitor is 0.01 KPa: 1% of 1% on the surface. In air, this will typically read around 0.04 – and typically higher in an enclosed room containing people.  
In rebreather operation, this should read 0 as the dive begins. Alarm values are set at 0.1 (alert) and 0.5 (alarm).

If any measurement (depth, time, PO<sub>2</sub>, PCO<sub>2</sub>) goes outside the acceptable range, the red light will flash and an alarm will sound, and a description of the problem will be shown in the bottom line of the display.

If the issue is then acknowledged by pressing the buttons, the alarm will cease for a short interval, while the light will remain a solid red. The problem value will then FLASH.

The result of this is that even in a "mask off" or otherwise visually compromised situation, the user, recalling the position of the different readings, may still identify and address a problem.

As soon as values are restored to an acceptable level, the light will return to being green.

Multiple issues may flash. Even if one problem has been acknowledged by the user, a new problem will result in a renewed sounding of the alarm (one problem does not "hide" another). As soon as the most severe problem is acknowledged, the alarm will sound for the next.

### **2.6.8. Diving and Surface Screens Available:**

From the Default screen, pressing the right button, the following screens can be seen and will cycle to the next screen with each push of the right button.

The display will revert to Default (Screen #1) after a few seconds if no buttons are pressed.

Presses	Screen	Purpose
0	#1: Default	Basic life support and dive information. Depth, Time, PO <sub>2</sub> , PCO <sub>2</sub> , Alarms.
1	#2: Three Sensors	Check if sensors are functional and in agreement. Individual PO <sub>2</sub> , mV output and status.
2	#3: Setpoint Switch	Enables user to select High, Low, or Automatic PO <sub>2</sub> setpoint.
3	#4: Dmax / Target / Temp	Maximum depth for current dive. Also, current PO <sub>2</sub> setpoint and sensor head temperature.
4	#5: Batteries	Voltages of both batteries. Typically, 3.9V. Minimum functional voltage around 3.6V.
5	#6: Time	Predicted remaining endurance on both batteries; current time and date
6	# 7: Alarm Levels	Current settings for depth, time, O <sub>2</sub> and CO <sub>2</sub> warnings.
7	#1: Default	Returns to the beginning of the cycle.

When an alarm is activated, giving a flashing light and audible alarm, you can continue handset operations, but if no button is pressed after three seconds, the Handset will switch to the Default Screen and display details of the alarm. The underlying alarm situation should be dealt with.

### 2.6.9. Surface Screens only

On the surface, the following screens are also visible in addition to the above and additional button presses from Screen #7, will lead to Screen #8, below.

**These are not available underwater.**

Presses	Screen	Purpose
7	#8: Start Surface Log	Begins recording a dive log (left button for Yes). Otherwise, logging begins automatically on passing 1 M.
8	#9: Shut down	Turns off Unit. Stops logging. Left button for Yes.
9	#10: Set Max Depth Alarm	Choose a maximum depth, below which a warning will be displayed, and alarm will sound.
10	#11: Set Max Time Alarm	Choose a maximum dive time, beyond which a warning will be displayed, and alarm will sound.
11	#12: Calibrate Depth Sensor	Calibrate depth to Zero. Useful for fine-tuning and for altitude dives.
12	#13: Calibrate O <sub>2</sub> 21%	For use during setup to calibrate O <sub>2</sub> sensors in ambient air. 2-point calibration is vital for the correct display and control of PO <sub>2</sub> .
13	#14: Calibrate O <sub>2</sub> 100%	For use during setup to calibrate O <sub>2</sub> sensors in pure oxygen. 2-point calibration is vital for the correct display and control of PO <sub>2</sub> .
14	#1: Default	Returns to the beginning of the cycle.

---

**Note: Options for turning off the Unit, changing alarm settings, and calibration, are NOT available underwater.**

---

The display will revert to Default (Screen #1) after a few seconds if no buttons are pressed.

Details of how to calibrate the electronics are found under "Calibration" below.

Details of how the unit maintains the PO<sub>2</sub> Setpoint, and how to change setpoint, are found under "Diving" below.

## 2.7. BCD and Harness

The Orca v6's harness (See Main Components), including the back plate, outer casing and Buoyancy Compensator Device (BCD) have been designed to make the Orca v6 as comfortable, adaptable, and versatile as possible. The backplate and foot give the harness its structure and are shaped to conform to the human body.

The Orca v6 is supplied with a standard five-point harness, which most divers will be familiar with, including shoulder straps, waist belt and a crotch strap. For security, the shoulder straps and carry handle are one continuous piece of webbing.

Quick releases are fitted on the shoulder straps and chest strap. D-rings are present for the attachment external equipment such as stage bottles. The chest strap, shoulder strap and crotch strap are all adjustable.

Mounted on the harness are the Outer Casing, BCD and Cylinders.



Looking at the inside of the Outer Casing you can see the Velcro pads that secure the counterlungs, and the internal trim weight pocket.

The cylinder straps, attached to the 'foot' of the backplate at the base, support the cylinders. Two cylinders are secured using a standard cam-band threaded through both strap guides.

The Outer Casing allows the user to resize the counterlungs to match their own tidal volume. See Section 5 Counterlung Sizing, below. It also protects the internal components from damage, while allowing rapid access.

The Wing BCD has 110N of lift and is shaped to fit the profile of the Unit. This allows it to expand sideways and forwards, not forcing the unit away from the back, which would interfere with the unit's breathing properties. The BCD retracts for streamlining when empty and has considerable volume lower down to help the user achieve both a level swimming position underwater and a head-out position on the surface.

The BCD kidney OPDV is mounted on the upper right-hand surface: this makes it easy to release gas while in a prone position. The power inflator and shoulder dump are on the left shoulder.

Note: The Exhale Counterlung dump cord is positioned on the **left** side by the cylinder valve.

---

**Warning:**  The BCD is held in place by the harness and must remain firmly attached to the rebreather. If it is not assembled correctly, it may not stay in place during a dive and cause a loss of buoyancy control or other problems. The standard harness allows for considerable variations in body size by means of the adjustable straps. Complete removal/replacement of the BCD or shoulder straps from the harness should only be performed by a certified technician.

**Warning:**  The BCD is not a breathing system. Gas should not be inhaled from the buoyancy compensator bladder.

---

## 3. Assembling the Rebreather

### 3.1. BCD & Harness

The Orca v6 comes set up on a standard back plate, foot, harness and integrated BCD.

The BCD is essential safety equipment as it provides the diver with a means to return to the surface. It should not be removed. The BCD is held in place by the harness. Correct assembly of the complete harness is a complicated process and complete disassembly should only be undertaken by qualified and competent service technicians. Adjustable shoulder/waist and crotch straps are provided to enable comfortable fitting for most users.

### 3.2. Installation of the Diluent System

The full installation of the diluent system only needs to be done during initial assembly – after this it can be left installed. However, this section serves as a convenient reference to ensure correct setup.

Taking the assembled Diluent System (see Diluent Supply System) with the Unit lying flat on the Harness, foot towards you, lay the Diluent hose assembly against the left side of the case with the first stage at the middle of the foot, connection thread facing the top of the machine.

Secure the Manifold Hose in place with the Velcro rolls between the outer casing and the BCD (see picture, point 1).

This Manifold comes to the top of the outer casing (2) The ADV can then be attached to the diluent system. First locate by hand, then tighten with a 17mm spanner taking care not to damage the O-ring by over tightening (3).

Take the Manual Add Valve supply hose and take off the MAV at the QD if connected. Thread this through the bungees on the underside of the BCD.

Thread this through the elastics and the top D-ring on the left shoulder strap so it hangs loosely. Reconnect the MAV hose at the QD and thread the MAV return hose parallel to the descending route. Follow the shoulder strap webbing through the BCD slot and tuck it in through the hole in the outer casing on the left side. It will hang inside the outer casing ready to be connected to the scrubber.

If the BCD Inflator Hose is connected via a 'triple' connector serving the Diluent MAV, attach as in the image on the right.

Lastly, arrange the pressure gauge.



If the standard “short” gauge hose is fitted, pass this between the waist pad and the waist strap at the position of the pull-down shoulder strap. Thread it from the bottom to top. It will then present forward and be available to the left hand when wearing the Unit.

If the long “over the shoulder” HP hose is fitted, this is threaded together with the MAV supply hose through the elastic bungee cords on the left of the BCD and then over the shoulder to hang with the diluent MAV. The overall layout is shown in an image below.

---

**Note: At this stage, use a 17mm spanner to ensure all connections in the diluent system are securely tightened. Blow into the diluent valve to ensure the diaphragm is seated properly and there are no leaks.**

---

Once fitted, the diluent system can be left installed in the Unit.

### 3.3. Installation of O<sub>2</sub> System

This full installation of the O<sub>2</sub> system only need to be done during initial assembly – after this it can be left installed. However, this document serves as a convenient reference to ensure correct setup.

To install the oxygen system, with the Unit lying on its harness, place the first stage regulator so that it sits at the midpoint of the foot, with the inlet facing the back of the Unit and the pressure gauge downwards towards the front of the machine.

Take the Manual Add Valve supply hose (the long one) and take off the MAV at the QD if connected. Then from the 1<sup>st</sup> Stage, thread this through the bungees on the underside of the BCD – not the top one! Thread it over the shoulder pad through the rubber retaining loops and the top D-ring.



Reconnect the MAV at the QD and thread the MAV return hose parallel to the descending route. Follow the shoulder strap webbing, then pass through the shoulder strap slot in the BCD and tuck it in through the hole in the outer casing on the right side (see picture right). It will hang inside the outer casing ready to be connected to the scrubber.

The shorter O<sub>2</sub> hose is placed inside the case and will eventually be connected to the Electronics Head when that is fitted later. It will supply the solenoid.

---

**Note: At this stage, go around the oxygen system with a 17mm spanner to make sure all connections are secure.**

---

Lastly, arrange the pressure gauge.

If the standard “short” gauge hose is fitted, pass this between the waist pad and the waist strap at the position of the pull-down shoulder strap. Thread it from the bottom to

top. It will then present forward and be available to the right hand when wearing the Unit.

If the long "over the shoulder" HP hose is fitted, this is threaded together with the MAV supply hose through the elastic bungee cords on the right of the BCD and then over the shoulder to hang with the oxygen MAV. Once fitted, the oxygen system can be left installed on the Unit.

### 3.4. Oxygen Cylinder

The oxygen cylinder sits below the Diluent Cylinder in the straps at the base of the Unit, with the valve on the right.



Make sure you are using the correct cylinder (green valve M26) and connecting to the correct regulator (chrome M26), green O-ring, on right of Unit.

---

**Note: Before installing, check the cylinder is in test & filled with sufficient 100% Oxygen for the dive.**

---

Attach the 1<sup>st</sup> Stage regulator, finger tight. adjust the hoses to point around 45° inwards, open the valve and check the pressure gauge.

Check the function of the Manual Add Valve.

---

#### **Note: Checking the Oxygen System**

- 1: Observe the gauge as you open the cylinder valve open to confirm it registers what is expected and listen for any noise of leakage.
- 2: Make sure the oxygen Manual Add Button is accessible and press it to check its function. This should result in a small hiss as the return hose pressurises, but no further gas flow if it is not yet connected to the scrubber.
- 3: Close the cylinder valve. Observe the pressure gauge and note its reading. The needle should remain steady. Leave the system pressurised and check again after the rest of assembly is complete.



### 3.5. Diluent Cylinder

The Diluent Cylinder sits above the Oxygen Cylinder in the straps at the base of the Unit, with the valve on the left of the Unit.

Make sure you are using the correct cylinder (black valve, G5/8 fitting) and connecting to the correct regulator (black handwheel, G5/8 on left of Unit).

---

**Note: Before installing, check the cylinder is in test & filled with appropriate gas for the dive. Analyse the gas to ensure it contains the desired mixture.**

---

With the Unit lying flat on a surface with the Foot curved up, slide the diluent cylinder into the straps at the base of the Unit, above the oxygen cylinder and with the valve to the left of the Unit, facing the tail end of the unit.

Before tightening the straps, rotate/slide the cylinder to ensure the valve points down to the diluent 1<sup>st</sup> stage. Attach the 1<sup>st</sup> Stage regulator, finger tight. Adjust the hoses to point around 45° inwards, open the valve and check the pressure gauge.

---

#### Note: Checking the Diluent System

- 1: Observe the gauge as you open the cylinder valve open to confirm it registers what is expected and listen for any noise of leakage.
  - 2: Make sure the Diluent Manual Add Button is accessible and press it to check its function. This should result in a small hiss as the return hose pressurises, but no further gas flow if it is not yet connected to the scrubber.
  - 3: Check the ADV. Press the button to see that gas exits. Breathe from the outlet and confirm that it is possible to receive gas with a hard Inhale.
  - 4: Close the cylinder valve. Observe the pressure gauge and note its reading. The needle should remain steady. Leave the system pressurised and check again after the rest of assembly is complete.
- 

### 3.6. Securing the Cylinders

Ensure that the diluent regulator points down and the oxygen regulator points up.

The cylinders should be pushed together to obtain an overlap of the cylinder bodies and reduce the width of the overall Unit.

The left cam band should be on the shoulder of the Diluent Cylinder and the right cam band should be on the shoulder of the oxygen cylinder, as shown in the picture above.

The cam bands are threaded and locked in as described below.

---

**Warning: It is important to thread the bands correctly otherwise the cylinders may become loose and detached from the Unit.**





In an already assembled Unit, after replacing the cylinders and connecting the 1<sup>st</sup> stages, make sure the pull dumps on the counterlung (cross toggle, left) and BCD (ball toggle, right) are accessible and operate (assuming the counterlungs are fitted)

### 3.7. Inhale Counterlung Installation

**Note: Check the Inhale Counterlung before installation.**

- Shake the lung and check for any dirt, liquid or debris inside.
- Visually inspect the O-rings for dirt and damage.
- Lubricate O-rings with Christolube.
- If all is correct, the lung is ready for installation.
- If any connectors are loose, tighten them.

After checking the lung, with the Unit lying flat on the BCD, open the outer casing



completely and place the lung on the right side of the Unit. Push the top edge of the Inhale Hose Connector through the right shoulder port of the outer casing. The oxygen hoses are also on this side of the machine - remember - "rich / right, lean / left."

Doing the same with both lungs (Exhale Counterlung shown) holding the lung in place with one hand, fold the flap of the Outer Casing over the lung and use your fingers to pull the Lung Breathing Hose Connector all the way through the hole as in the photo below.

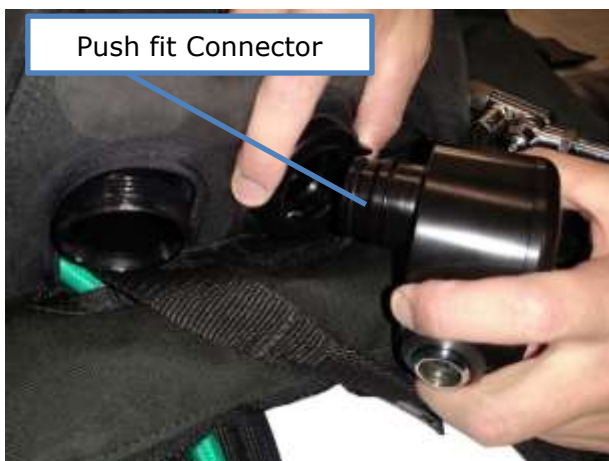

With one hand inside the case, position the female Push Fit Connector of the Inhale Counterlung through the central port of the Outer Casing. Hold the lung in position and push the ADV male connector into the Push Fit Connector. You should hear a click. Be careful to ensure it is properly seated and has not trapped the fabric surrounding the Port between the two mating parts.

Finally, check the position of the Inhale Counterlung inside the case and make sure the Velcro panels match up with the Velcro panels inside the Outer Casing, bottom edge to bottom edge. Press the Velcro together.

An image of both lungs installed together is shown below.

### 3.8. Exhale Counterlung Installation

---

**Note: Check the lung before installation.**

---

Shake the lung and check for any dirt, liquid or debris inside.

Check that the Counterlung OPDV Valve Base is tight.

Check there is no scrubber material or other debris that may prevent a seal on the mushroom valve and that the Mushroom Valve is in good condition. Correct in the image below.



Visually inspect the O-rings for dirt and damage. If all is correct, the lung is ready for installation.

If any connectors are loose, tighten them.

Place the cap of the counterlung OPDV – insert the Locking Cord and pull on the cap to make sure it is seated correctly and fixed firmly in place.



With the Unit lying flat on the BCD, open the outer casing completely, place the Exhale Counterlung on the left side of the Unit. Push the top edge of the Exhale Hose Connector through the left shoulder port of the Outer Casing, pull it through with your fingers from the outside.

The diluent hoses are also on this side of the Unit (remember - rich on the right, lean on the left).

Note: Check the position of the Exhale Counterlung inside the case and make sure the Velcro panels match up with the panels in the Outer Casing. Press the Velcro together.

The overall layout of the lungs is shown below:



1	Oxygen MAV return Hose	4	Diluent MAV return Hose
2	Solenoid Hose	5	Exhale Counterlung
3	Inhale Counterlung	6	OPDV pull cord threaded through diluent hoses

### 3.9. Breathing Loop

Once the counterlungs are in place and the Diluent Valve attached, you can check and attach the Breathing Loop.

#### 3.9.1. Checking the Standard Breathing Loop

**Warning:** Correct flow direction and functioning of the one-way valves must be checked before installation. Directional flow through the rebreather is vital for maintenance of a life-supporting breathing mixture.



Verify the Dive/Surface Valve shutoff is in the ON position (DSV Lever to the right), place the mouthpiece in the mouth and breathe in and out.

Then, alternately block the ends of the Inhale and Exhale Hoses with your hands or press them up against your cheeks. Inhale and exhale for each hose to check that gas flows in the correct direction only. Listen for any leakage that might indicate the need to clean or replace the valves.

If the breathing hose on your right-hand side (Inhale Hose, black fitting) is blocked, it should not be possible to breathe in. No air should enter, not even a small amount. Any leakage may indicate a fault (dirt or damage) with the Exhale valve.

If the breathing hose on your left-hand side (Exhale Hose, red fitting) is blocked, it should not be possible to breathe out. No air should exit, not even a small amount. Any leakage may indicate a fault with the Exhale Valve.

If either of the above tests have failed, check to see if the shutoff is fully ON and repeat. If leakage persists, there may be dirt on the sealing surfaces of the valves, or they may be damaged. See Care and Maintenance section.

---

**Note: If a malfunction is suspected underwater, squeezing the hoses alternately and checking for noise and resistance during the inhale and exhale cycles serves the same purpose.**

---

Check the hoses for sealing with the DSV in the "off" position, DSV turned to the left. Blank off the Exhale Hose and blow into the end of the Inhale Hose. Switch the hoses, blank the Inhale Hose, and pull a vacuum on the Exhale Hose. In neither case should any gas enter or leave the system. Any leakage at this point may indicate damage to the O-ring seals of the Dive Surface Valve, or simply damage or loose attachment of the hoses. See the Care and Maintenance section.

---

**Warning:**  **It is important to know the valves function properly, as if they were damaged, mis-installed or missing, the user could breathe directly in and out of the counterlungs without the gas passing through the CO<sub>2</sub> scrubber or being analysed by the Electronics. In this circumstance the rebreather would not provide a breathable gas mixture, resulting in unconsciousness and possibly death.**

---

### 3.9.1.1. *Installing and Checking the Mouthpiece Bite*

---

**Note: The Orca v6 is supplied with a mouthpiece already attached.**

---

Install a mouthpiece onto the mouthpiece opening, and lightly fasten the supplied cable tie (179 mm x 4 mm) onto the mouthpiece bite groove. To ensure the correct tension is applied when securing, tighten the cable tie until the tail protrudes 49mm. Snip the extra length with a small pair of scissors or wire cutters.

It is vitally important to inspect the Mouthpiece Bite before diving, to ensure it is securely attached and that there are no cracks or damage.

- A leak here may result in a steady inflow of water to the Unit and will not be detected during the standard positive and negative tests.

- Leakage can be tested on a breathing loop by blocking both hose ends and exhaling hard. Listen for any air escaping from the mouthpiece.
- Leakage can be tested on a fully assembled rebreather simply by exhaling hard into the Unit until it is completely full. Maintain your exhale pressure and listen for any air escaping from the mouthpiece.

**Warning:**

**A leaking mouthpiece may result in a steady inflow of water to the Unit and will not be detected during the standard positive and negative tests.**

**If the Mouthpiece Bite needs to be replaced, only use the standard part supplied by LDS, which matches the shape of the mouthpiece body.**

### 3.9.2. Installing the Standard Breathing Loop

At this stage, you should have the counterlungs installed.

Arrange the breathing hoses with the inhale hose / black fitting on the right, (when the Unit is viewed from the back), and the exhale hose / red fitting on the left (see Breathing Loop).

The black fitting screws onto the right port and the red fitting screws onto the left port.

The ports cannot be cross connected as the black (Inhale) fitting will not enter the left (Exhale) port, and the locking nut will not engage.

A feature of the hoses is that their "twist" can be adjusted to vary the angle of the mouthpiece in the mouth. Twisting the fittings once plugged into the rebreather will adjust the angle of the mouthpiece.

Once the hoses are fully screwed in, adjust the twist of the hoses at the counterlung connection end, so that the mouthpiece sits at the correct angle in the mouth. If the mouthpiece is horizontal when the Unit is laid flat, it should give a comfortable fit for most people.

A useful guideline for this is the "seam" on the hoses. The loop is supplied with the seams starting at the upper edge of the hose at the mouthpiece. The hose fittings should be twisted so that the seams point horizontally inwards by the time the hoses reach the Unit. This should be matched by the position of the rear hose clips, which should now point inwards so as not to risk snagging during a dive.

**Note: You can put the Unit on your back at this stage and check that the hose alignment is indeed comfortable and adjust accordingly.**

## 3.10. Scrubber

**Warning:** Before fitting the Scrubber, it must be filled with fresh Sofnolime!



**This is required to remove carbon dioxide during the dive and is necessary for the rebreather to maintain a life-supporting gas mix.**

### 3.10.1. Filling the scrubber

Filling and assembly steps are as follows:

**1. Add the bottom dust filter.**

Make sure no Sofnolime is underneath, and make sure the edges are well pressed down into the lower edge of the canister so that no Sofnolime will fall underneath during filling.

**2. Slowly add Sofnolime to around  $\frac{3}{4}$  full.**

Pour slowly and use a circular motion to ensure an even distribution of sof nolime in the canister. Do not attempt to fill the canister entirely at this stage.

**3. Compact the sof nolime.**

Before using the scrubber, the material must be shaken down and any gaps filled in. If this is not done, gaps may form in the scrubber from shaking during transport, resulting in a breakthrough, i.e., un-scrubbed gas bypassing the material.

Observe the fill-line of the canister – the ridge closest to the Sofnolime 797 1-2.5 mm itself in the picture below.

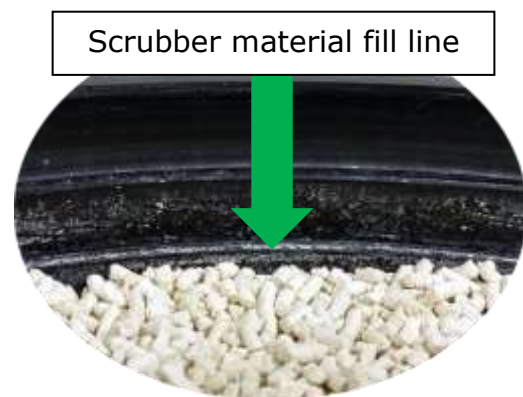

---

**Warning:**



**Never fill any higher than this. The gap between this ridge and the next allows sufficient space for the Scrubber Sponge to achieve the correct compression and hold the scrubber material in place. If filled higher, the scrubber may not close properly and may leak.**

---

The grid also rests on the fill line allowing the scrubber to be shaken down and further compacted.

First, place the Top Grid onto the fill line. Then, hold the grid in place. Be careful to put your thumbs on the metal framework rather than the mesh. Then, lift the scrubber into a vertical position and give short shakes for not less than 10 seconds. You will quickly get the feel of the motion that causes the scrubber to settle. Bigger motions will simply slosh it around and cause it to become even less compacted.

Carefully putting the scrubber back on the work surface and lift off the Top Grid. You should see an obvious cavity at the top that can easily be filled with more scrubber material (and simulates what might happen in a rough boat ride or any situation where the Unit is stored vertically, and the scrubber might potentially settle).

Repeat the shaking and filling process. After a few short cycles of this process, it will become impossible to add any more scrubber material, indicating that the scrubber is full and will not suffer from settling or bypassing issues in use.

Once this point has been reached, rotate the Top Grid clockwise and anti-clockwise to ensure the scrubber material is evenly distributed.

---

**Note: Ensure you tightly close the Sofnolime keg so that remaining material does not absorb ambient CO<sub>2</sub> and become depleted.**

---

#### 4. Cleaning the sealing surfaces.

Leaving the Scrubber flat on the work surface, make sure the sealing surfaces for the Scrubber Lid and the ridge for the Top Grid are clear of dust, scrubber material and other obstructions.

Likewise, remove the O-ring, check and clean the sealing surface on the Scrubber Lid, lubricate the O-ring with Christolube, and replace.

---

**Note: Although not a high-O<sub>2</sub> environment, this O-ring should be lubricated with Christolube to avoid lubricating a silicone O-ring with SGM494 silicone grease.**

---

#### 5. Adding the Scrubber Sponge, Fabric Mesh Disk, and Top Grid.

Place the Sponge, then the Fabric Mesh Disk and then the Top Grid on top of the scrubber material.

The sponge serves to ensure the scrubber material remains evenly compressed. The fabric mesh disk between the two serves to absorb any condensation generated on the lid of the scrubber that might dribble down into the material.

---

**Warning:** It is vital that all these components are installed in the correct order or the Scrubber Material may become loose, causing incomplete filtration of the breathing gas.

---



#### 6. Closing the Scrubber.

---

**Note: Make sure the grid is positioned centrally relative to the Scrubber canister.**

---

Check all O-rings are present and in good condition on the Scrubber Lid Bolt.

Ensuring the grids and sponges remain centred, align the corner of the Scrubber Lid with the corner of the sealing area on the canister. Push this area into place and follow by pushing the other side of the Scrubber Lid until the Scrubber Lid O-ring pops into place and the Scrubber Lid is fully closed.

Doing it in this order removes the possibility of misalignment or pinching the O-ring. If excessive force is required at this step, something (the Scrubber Lid itself, or the grid underneath) is misaligned.

Finally, screw in the bolt, hand-tight to secure the lid in place. Throughout this process hold the lid down by hand. Do not use the Lid Bolt to clamp the lid in place.

---

**Note: Never rely on the bolt to pull the lid down into place itself.**

---



## 7. Checking the scrubber.

Check that the Lid is thoroughly closed all the way round. If it is not, push it down by hand and then tighten the bolt further. Do not use the bolt to tighten it – if it will not move under hand pressure, something is jammed!

Give the scrubber a strong shake and listen for any movement of the material inside. There should be no noise – if there is, check levels of scrubber material, fill and fit again.

Once successfully accomplished, the scrubber may either be installed in a Unit or sealed inside an airtight bag for later use.

or fitted to the Unit with the Electronics Head in place and the breathing loop fitted and closed.

---

**Warning:** Do not leave a filled scrubber canister open to ambient air for lengthy periods of time, or it may absorb ambient CO<sub>2</sub> and become depleted. If fitting to the Unit, install the Electronics Head and close the breathing loop as soon as is practical.

---



### Scrubber filling flow chart

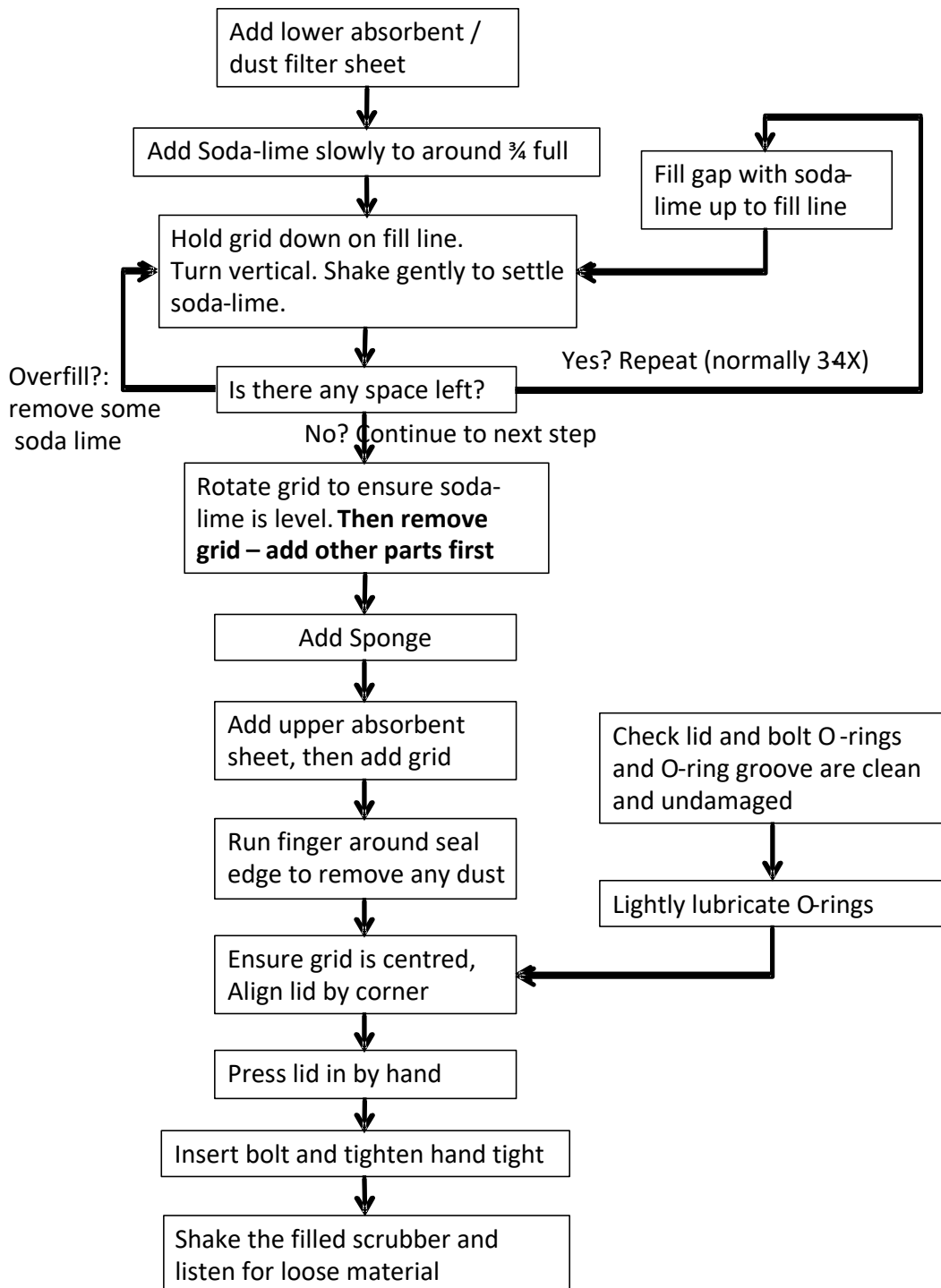

### 3.10.2. *Installing the scrubber*

You should now have the main structure of the Unit assembled and a FILLED scrubber as described in 'Filling the scrubber' above.

---

**Note: Do not attach the scrubber unfilled unless for storage or display, and never attach a partially filled scrubber.**

---

Visually inspect the sealing surfaces on the canister (inhale port, exhale port, and Electronics Head area) for any dirt or damage, and visually inspect the O-rings on the counterlungs to make sure they are clean, lubricated (Christolube), in the correct positions (not in the Locking Groove) and free of dirt or damage.

**Warning:**



**Make sure that all O-rings are in the positions shown and not in the locking groove, or they may become trapped or severed.**

---

Visually inspect the Manual Add fittings on both sides to ensure they are fixed securely in place.

Remove the White Locking Clip from the scrubber as shown below and keep it in a safe place.



Placing a hand behind the counterlungs, gently but firmly insert both connections all the way into the scrubber (the Exhale Counterlung Connector above and the Inhale Counterlung Connector below).



Once both counterlung connectors are fully inserted, replace the White Locking Clip into the holes in the top of the canister. The clip should go in easily - if it does not, the connectors are not properly seated. Remove and verify the connectors are properly seated, the O-rings are in the correct grooves, and try again.

Connect the two Manual Add Valve hoses of the oxygen and diluent to the swivel connections on the sides of the scrubber as shown below left.

After making the connections, move the red O-rings up behind the locking sleeves to prevent them becoming dislodged during the dive. See Oxygen First Stage & Downstream Components

The scrubber is now installed the Electronics Head should be attached in order stop exposure of the scrubber material to the atmosphere.

## 3.11. Preparing, Fitting and Removing the Electronics

### 3.11.1. *Checking the Handset*

The handset will arrive connected to the Electronics Head with the Handset Cable.

The connectors of the handset and the handset cable are wet-mateable and lubricated with SGM494 silicone grease to protect the contacts from corrosion and seawater ingress.

If disconnected, connectors should be secured with the cable locking sleeves provided.

It is recommended that the handset (standard or large) is left connected to the main electronics.

If they are disconnected it is recommended that the bulkhead connectors are protected with Blanking Caps. These are not supplied and are available from our website or an authorised dealer.

### 3.11.2. *Checking Cables and bulkhead connectors*

Bulkhead connectors in the A1 and A2 models are supplied with Blanking Caps which are secured in place with locking sleeves. When not in use the Blanking Caps and locking sleeves must be kept attached to protect the pins and sockets of the bulkhead connectors.

The locking sleeves are also used to secure offboard monitoring connection cables.

---

**Warning:** **If you have analogue ports that are not in use, these must be covered with a blanking cap and locking sleeve.**



**If you are operating any offboard devices such as a dive computer or head-up display, follow the manufacturer's instructions for making connections and use.**

---

### 3.11.3. Checking the Electronics Head

First carry out the following basic checks:

- Check that sensors are in date.
- Check that O<sub>2</sub> inlet fitting and swivel are tightly attached.
- Check that O-rings are clean and intact.
- Check that all cables are fitted or blanked, and all connections are secure.
- Check that the Unit has been fully charged

### 3.11.4. Calibrating the Sensors

The Orca v6 Calibration Cap (right) gives you a straightforward way to rapidly and accurately calibrate the Oxygen Sensors with minimum wastage of gas.

With this system, there is no reason not to calibrate the sensors in 100% oxygen before every day's diving. This is best practice and ensures accurate and consistent readings from the sensors throughout their operational range.



The Calibration Cap can also be used to apply positive pressure (see below) and be used to protect the sensors from dirt or impact during storage or transit.

#### 3.11.4.1. Calibrating in 100% Oxygen

##### Step 1: Equipment

You will need the following items:

- Orca v6 Electronics Head with sensors and Sensor Guard installed.
- Calibration Cap.
- Supply of pure oxygen at 7-10 bar with a quick release / BCD connection (for instance, the Orca v6's own internal oxygen supply).

##### Step 2: Turn on the electronics.

Turn on the electronics from the handset and run through the start-up menus, observing the date of last calibration. This can be recorded in your logbook.



At this point, **DO NOT** attach either an oxygen supply or the Calibration Cap. The sensors will show readings for normal air and ambient pressure.

**Step 3:** Prepare the 100% oxygen supply for the next step by connecting the Calibration Cap to the oxygen supply and **gently** turn on the gas. You should hear a steady flow of oxygen through the orifice.

**Warning:** Do this before putting the Calibration Cap over the sensors. This prevents the possibility of squirting any water in the supply hose over the sensors.



**Step 4:** Gently place the Calibration Cap over the Sensor Guard. It should fit snugly in place without requiring any force.



**Do not** press down on the Calibration Cap during this operation. The O<sub>2</sub> needs to displace the other gases in the sensor area, which must escape around the edge.

If internal pressure exceeds 1 m above ambient, the Unit will enter Dive Mode and refuse to calibrate (if the dive log has activated, time is counting) and the Unit will need to be restarted.

Make sure that Time (top right corner) is "0:00." If the clock is counting, logging has begun, and you must restart the Unit and begin again.

**Note:** The system does not allow calibration under pressure, to avoid the risk of accidental calibration during a dive. However, after calibration you can use the Calibration Cap to verify functioning of the sensors under pressure. See "Verification of Sensors under Pressure".

**Warning:** You must allow the PO<sub>2</sub> readings on the handset to stabilise before calibrating.



**Step 5:** From the home screen you will see that within a few seconds, the oxygen readings should stabilise, at slightly over 1.00 in a recently calibrated Unit. This is due to the slight pressure from the flow of oxygen within the Calibration Cap.



**Nearly ready:**  
PO<sub>2</sub> rising, PCO<sub>2</sub> falling



**Ready:**  
PO<sub>2</sub> stable, PCO<sub>2</sub> zero

When Oxygen Sensors are changed, **you must calibrate them.**

**Warning:** If you change an Oxygen Sensor you must calibrate the Unit. If you do not, the previous sensor's parameters will remain stored and be used by the control software, giving false readings.



In this case, a sensor has been changed, here sensor 3, and both the "O2 Range" alarm and "O2 Sensor Error" alarms are shown (below).



**O<sub>2</sub> Sensor Error**



**Screen #3 detail**

Looking at the individual readings shows that a new cell in position 3 is reading too high and has been rejected by the controller for giving an oxygen level impossible at the ambient pressure (it is not possible to achieve a PO<sub>2</sub> of 1.27 bar when ambient pressure is only around 1 bar). However, there is nothing wrong with its millivolt readings - being new, it has a stronger output than its predecessor. Calibration will return the machine to normal function.

With a constant low flow, allow the readings to stabilise (even if different), use the right button to scroll through the menus to screen #14 and use the left button to select "Calibrate 100% O<sub>2</sub>", and then "YES" as below.



Example of calibration with a changed sensor (Sensor 3)

Example of routine calibration with functioning sensors



**Step 6**

The Unit is now calibrated and will shortly return to the main screen. Press the right button to check that the readings are in the region of 1.00 (or slightly above due to the greater pressure under the Calibration Cap) and that all the Oxygen Sensors are consistent.



To finish up, remove the Calibration Cap from the head and disconnect the O<sub>2</sub> supply. replace the small rubber Dust Cap on the Calibration Cap’s inlet to prevent contamination.

Prepare your Unit for diving or storage as required.

**3.11.4.2. Calibration in Air (21%)**

The Orca v6 electronics use two-point calibration to aid in accurate oxygen measurement.

Unlike high-end calibration, which should be done in the 24 hours prior to diving, air calibration is necessary only when any of the oxygen sensors do not indicate 21% in ambient air.

---

**Note: You must calibrate in 100% Oxygen before calibrating in air!**

---

Prepare the Unit, with the electronics switched on, sensors exposed to freely circulating ambient air. If indoors, make sure you are in a well-ventilated room.

Scroll through to Screen #13, where you will be asked if you want to calibrate the Unit in Air. Respond Yes and follow the on-screen instructions to complete the calibration in air.





At the end of the calibration the Unit will revert to the home screen. A small presence of CO<sub>2</sub> is normal in ambient air.

---

**Warning:**



**It is important that Air calibration is always done with the Electronics Head exposed to Ambient Air - not while attached to the rebreather, where an elevated oxygen level might be possible.**

**If the Air calibration point is artificially high, this will affect the calibration slope of the sensors and the Unit will under-read PO<sub>2</sub> at levels above 1 bar, which could put the diver at risk of hyperoxia.**

---



---

**Note: After air calibration, the cells will not necessarily register 0.21, as the calibration is pressure compensated. At altitude, lower results will be shown. This is normal and does not affect the functioning of the machine.**

---

### 3.11.4.3. Calibration Issues

If the Unit displays "Calibration Fail":

- Repeat the procedure and ensure the sensor readings have truly stabilised before a calibration is made.
- If the problem persists, a Sensor (indicated) is likely to be faulty or the gas is not 100% oxygen (during oxygen calibration).
- The Pass/Fail criterion for the Air calibration is based on the values recorded during the Oxygen calibration. If an Air calibration persistently fails in fresh air, the reason may be a previous Oxygen calibration at a concentration of less than 100%. Therefore, repeat the Oxygen calibration and then reattempt calibration in Air.

If the system refuses to calibrate despite all correct procedures being followed, the following possibilities exist:

- One or more Sensors may be damaged or old and are out of range.
- The PO<sub>2</sub> of the calibration gas is too low (i.e., the voltage from the sensors is lower than expected for the gas indicated).

The performance of the sensors can be verified by observing the readings of the individual Sensors on the three-sensor screen (Screen #3) view, in 100% oxygen, and while ambient pressure is varied. This may highlight a current – limited sensor, one with

an intermittent signal, or one with a slow response time. The system will not allow a sensor to calibrate if the ADC count is less than 1000 in pure oxygen.

---

**Note: If there is doubt about the gas, it can be cross-checked against certified gases produced by distillation.**

---

#### **3.11.4.4. Calibration of the optional 4<sup>th</sup> O<sub>2</sub> Sensor**

**If a fourth independent cell is used**, perform a calibration according to your computer or PO<sub>2</sub> meter's instructions.

Ensure that the 4<sup>th</sup> cell is exposed to the same gas concentration as the main three cells. This may be as follows:

- 1) First, conduct your 2-point calibration of your 3 main sensors as above.
- 2) With the 4<sup>th</sup> sensor fitted as above, and your PO<sub>2</sub> monitor or computer installed on the Analogue Output, install the Electronics Head on the rebreather.
- 3) Inject oxygen using the Manual Add Valve and flush the loop until the main sensor and 4<sup>th</sup> sensor readings stabilise.
- 4) Calibrate to your own offboard device as per your manufacturer's instructions

This may provide your 100% calibration point.

---

**Note: Other calibration points should be set according to your monitoring device manufacturers instructions.**

---

#### **3.11.5. Verification of Sensors Under Pressure**

The Orca v6 allows the user to confirm that the sensors can register partial pressures significantly higher than 1 bar, as they will need to during an actual dive.

Only perform this step after having first completed two-point calibration (100% oxygen first and then ambient air). If the calibration is not completed first the readings under pressure will not be reliable.

**Step 1:** Once the Unit is calibrated, and the Calibration Cap is entirely flushed with pure oxygen (reading stabilised) the user may carefully but firmly hold the Calibration Cap down on the Unit, to boost the internal pressure.



Here, 2.4 m is equivalent to 1.24 bar. If the gas mix is 100% O<sub>2</sub>, and the sensors read 1.24, you know they read correctly up to that level.

By comparing the oxygen readings to the depth readings, you can have as much certainty as possible that the sensors will indeed be giving you true readings in their operational range.

As this procedure simulates a dive, (note the time on the clock at top right) it will be logged by the system, giving a record that it was calibrated correctly.

By pressing the right button, to see the three sensors together, consistency can also be checked (in the following picture).



**Caution:**



**DO NOT suddenly release the pressure: this may cause damage to the sensors.**

**Step 2:** Turn off the oxygen supply, wait for the pressure to return to zero, then remove the Calibration Cap. To avoid any risk of damaging the sensors, do not rapidly release the pressure. The oxygen level should fall back to ambient.

Remove the Calibration Cap and replace the Dust Cap to prevent any risk of contamination. Put the Electronics Head back in its case or proceed to assemble the Unit ready for diving.

### 3.11.6. *Installing the Electronics Head*

Before attaching the Electronics Head, turn it on and check that:

- The electronics have been calibrated in last 24 hours (as shown by first screen after start-up) - if not, calibrate it using the Calibration Cap and system's own oxygen (see section Calibrating the Sensors).
- All batteries are charged (Electronics Head, Valve Battery, any attached computers or other equipment) and have sufficient predicted duration beyond that anticipated for the dive intended. Ideally, this should be 3.9 volts or more.
- No system errors are displayed, and no alarms beyond "PO<sub>2</sub> LO" and possibly "CO<sub>2</sub> Warning" if indoors or breathed upon. If errors are present, refer to the Troubleshooting section below.
- The Unit can read 100% in pure oxygen, and over that value if pressurised.

If all is OK, the module can be attached.

- Turn the system off.
- Visually check and grease the main O-ring and oxygen probe O-ring with Christo-Lube as shown below.



Make sure there is nothing that might prevent a seal or damage the O-rings on the O-ring sealing surfaces of the scrubber. Align the module and press it firmly in place as shown below:

Once the module is correctly seated, tighten the Head Bolts on either side.



- Check that the oxygen inlet elbows and quick-disconnects are attached (use 17 mm spanner and 5 mm Allen key if necessary) and that the O-rings are seated to prevent the hoses from coming loose during a dive.
- Check that the connections to the handset and any external computers are tight and secure at both ends (hand tighten only).
- Check that the White Scrubber Clip is in place in the Scrubber.
- Check that all ports on the electronics - the USB Port, the blank plug if no 4<sup>th</sup> O<sub>2</sub> Sensor is used - are blanked, and any unused external Bulkhead Connectors are capped are securely closed or sealed.

Insert the module into the top of the scrubber, making sure that the oxygen probe aligns with the corresponding hole.

If the module is inserted the wrong way round, the locking bolts will not line up.

Once the module is completely inserted, tighten the Locking Bolts equally so the Electronics Head is fixed securely in place.

Attach the Solenoid Hose and move the Locking O-ring in place so that the hose cannot be accidentally disconnected.

Reconnect any Manual Add Hoses you have had to disconnect to add the electronics and replace locking O-rings next to the locking sleeves.

Clip the Handset and any computers to the nearest shoulder D-ring for safe keeping.

### 3.11.7. Removing the Electronics Head

Pulling the canister open by the oxygen fitting or the handset cable can put stress on the oxygen probe:

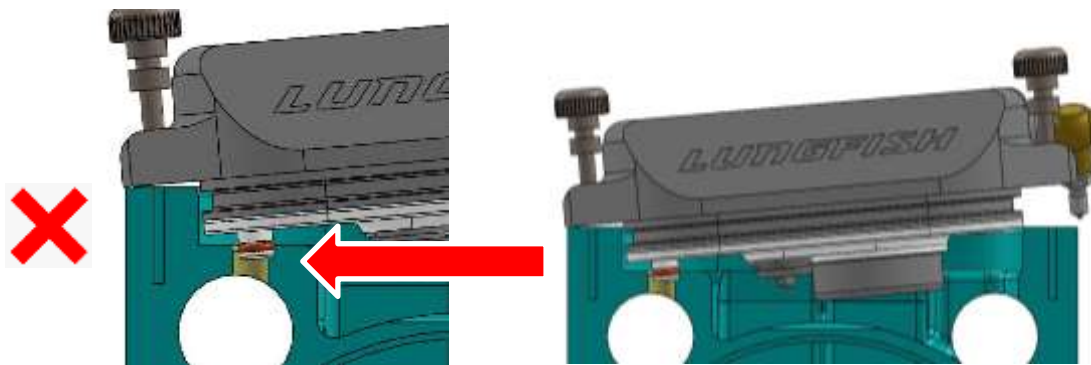

Opening by pulling both sides at the same time and remove in a straight line (below right).

If it is not possible to apply sufficient force to lift the electronics evenly, with the Scrubber Lid facing you, lift by the left-hand side head bolt first.

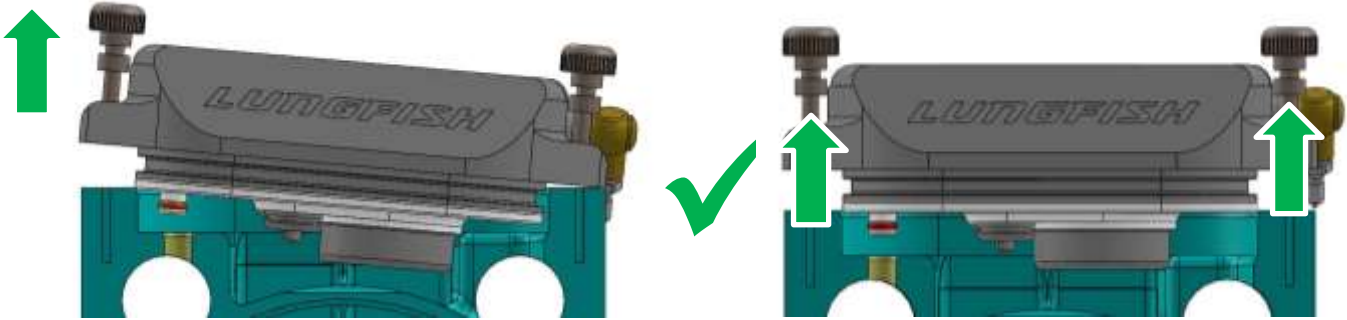



## 4. Pre-Dive Preparation

---

To ensure a successful dive, after following the assembly sequence above, including filling the scrubber, perform the following checks to make sure your Unit is fully functional. See also the Summary Preparation Checklist below.

**Warning:** These checks must be completed successfully to ensure that the Unit is operating properly. Failure to perform them could lead to injury or death. Your life depends on them.



A checklist covering the below procedures is provided at the end of this document.

### 4.1. Pressure Checks

Once all the components are installed, turn on your cylinders and check you have sufficient and correct gases for your planned dive, rectify if not. This assessment depends on your training, knowledge and understanding.

#### 4.1.1. Positive Pressure Check – Standard Loop

Turn the gas supplies off and vent using the MAVs to remove the possibility that a leak inward from the LP system might disguise a leak in the loop.

Switch the DSV to the ON position and inflate the Unit using your mouth, inhaling through your nose. After a few breaths, it should inflate the counterlungs to their maximum size after which any further inflation will only lead to air releasing from the OPDV, with considerable resistance. Close the DSV to seal the loop and remove from your mouth.



Leave for not less than 30 minutes to ensure the system retains pressure.

If it sinks down, something is not sealed. This test should be performed before a dive. If there is the suspicion of a small leak, the Unit may be left inflated to see if the volume in the counterlungs changes.

If the Unit deflates, remove and reassemble and repeat the above test.

---

**Warning:** If it is not an assembly issue, do not dive. Contact an Orca v6 certified service technician or contact the factory.



---

Pulling the OPDV toggle should also release the pressure.

#### 4.1.2. Negative Pressure Check – Standard Loop

Turn the gas supplies off.

Switch the DSV to the ON position and suck all air out of the counterlungs using your mouth, exhaling through your nose. At some point, it should become impossible to inhale further as the lungs will be completely deflated as in the picture (right).

With the mouthpiece still in your mouth and trying to inhale on it, pulling the OPDV cord (right) should NOT allow you to inhale or allow leakage of air back into the counterlungs.

If it does allow air into the breathing loop, check the mushroom valves in the Exhale Counterlung OPDV are in good condition and seated correctly and repeat. If the mouthpiece is now OFF and removed from the mouth, the Unit should remain empty, and the counterlungs should retain a crushed appearance.



## 4.2. Pneumatics Check

- 1) Gas supplies: Turn gas supplies on and confirm pressures on your gauges. Analyse gasses to confirm gas composition.
- 2) Gas Addition: Check MAVs and ADVs function by pressing buttons.
- 3) Confirm there are no leaks: Note pressures on gauges. Turn off the gas supplies. Check gauges remain steady to confirm no gas is escaping.

A checklist is provided to confirm these tests.

You must check the functioning of the main systems, before using it for a dive. Turn the electronics and gas supplies on.

At this stage you should be able to answer all the electronics start-up questions positively. If not review the above procedures before continuing.

Having successfully completed the above checks, it is now possible to breathe from the Unit.

- The electronic controller should add oxygen and stop doing so when PO<sub>2</sub> reaches 0.6 (this process may be accelerated by breathing through the Unit to circulate the gas over the sensors).
- The MAV buttons should add gas – press and listen for gas flow.
- The ADV or HDV should add diluent if the button is depressed, and the ADV should add gas in response to suction. Press the button and listen for gas flow.

The BCD and Bailout Mouthpiece (if fitted) should work.

---

**Warning:** If any of these checks is not positive, correct the fault before diving.



---

Turn the Unit off to conserve the battery and continue to counterlung sizing.

### 4.3. Counterlung Sizing

Adjust the Unit's counterlung volume to match your own tidal volume.

---

**Note:** This is a critical step - correctly sized counterlungs will offer you comfortable breathing, ease of buoyancy control and increased protection from hypoxia during the dive.

---

#### 4.3.1. Counterlung Sizing with Standard Mouthpiece

---

**Caution:** Do not breathe in and out of the system for long without a gas supply, as you will be depleting the oxygen inside! Performing this section with the electronics turned on guards against this risk.



- 1) Turn all gas supplies off. Turn electronics on for safety reasons.
- 2) Suck all gas out of the Unit by going on the loop, inhaling through your mouth and exhaling through your nose until empty. Close the loop with the DSV, then breathe normally.
- 3) When ready, inhale fully ONCE through your nose, go in the breathing loop and exhale fully through your mouth into the Unit. Breathe normally on the Unit. You should be comfortable breathing from the Unit.
- 4) Exhale fully into the Unit, switch the mouthpiece to the OFF position and do up the side Velcro flaps tight so they 'stick' to each other. Next add any trim weights required, lift the bottom flap and then fold down the top so they overlap and 'stick' without leaving any loose material.
- 5) Breathe from the Unit. If not comfortable, repeat the process, exhaling more gas into the Unit.
- 6) Add trim weights as required and close Outer Casing tightly over lungs.

---

**Note: You should be able to breathe from the Unit without resistance but be able to “touch” the top and bottom of the counterlung by deep breath in or out.**

---

The Unit should now be sized to match your tidal volume.

#### 4.4. Weights

**Warning:**



**It is the responsibility of the diver to ensure that the ORCA v6 is never weighted in such a way that it is not possible for the installed buoyancy device to overcome the weight of the unit plus any diver-added non-detachable weights, and still provide enough positive buoyancy at the surface to keep the divers head well above water. Consult your instructor, dealer with any questions or concerns. Failure to maintain positive buoyancy at the surface with the ORCA v6 can lead to serious injury or death.**

---

Weighting the rebreather itself, rather than relying solely on a belt, improves ease of movement and comfort (including reducing work of breathing) during the dive by keeping the Unit and its counterlungs close to the back and allowing adjustment for level / neutral trim in the water.

Before closing the Unit, you can add a trim weight to the top pocket inside the case. For initial pool dives, most users use a 2 kg shot pouch. If you have not added the trim weight already, open the top and bottom flaps only, add the weights, and make sure the lungs are fully inflated against the side flaps, so the volume you have set for yourself remains accurate.

---

**Note: For most divers, total weighting is similar to that needed with a 12 or 15 litre steel cylinder in the equivalent diving conditions. Always do a weight check before diving.**

---

## 5. Diving the Orca v6

---

### **Warning: Do Not Dive without Training**



The Orca v6 is a very capable life support system, however, its use requires appropriate training. Reading and understanding the below information is **IN NO WAY** a substitute for proper training.

**Diving a rebreather without training can be fatal.**

---

### 5.1. PO<sub>2</sub> monitoring and control

In rebreather diving, the main concern is not the quantity of the gas in your cylinders, which decreases slowly and at a steady rate, but the actual concentration (partial pressure) of oxygen in the gas you are breathing. The human body is effectively incapable of detecting the concentration of oxygen. Too little, and indeed too much, will rapidly result in unconsciousness or death, with little or no prior warning. Therefore, the prime role of the control system is to maintain the correct oxygen level, and you as the diver must remain continuously aware of what you are breathing.

---

### **Warning: The first rule of rebreather diving is ALWAYS KNOW YOUR PO<sub>2</sub>.**



**This is absolutely critical to your survival. You must be able to read your display at all times, and you must understand the functioning of the automatic PO<sub>2</sub> controller as well as how to adjust PO<sub>2</sub> manually.**

---

The Orca v6 electronics measure, display, and control the partial pressure of oxygen (PO<sub>2</sub>) in the diver's breathing mixture during a dive. This relies on functioning and correctly calibrated oxygen sensors. The user must always be aware of their PO<sub>2</sub>, and always have the ability to adjust PO<sub>2</sub> manually.

#### 5.1.1. PO<sub>2</sub> Monitoring

The system always shows the current PO<sub>2</sub> on the default display, and also alerts the diver if the PO<sub>2</sub> becomes dangerously low or high, with an audible alarm, a red flashing light, and messages and highlighting of the problem value on the screen.

The diver should always keep the screen readily visible: its bungee cords are designed to attach it to the back of the right hand, and its optically corrected screen ensures that the readings can be seen even from a shallow angle underwater.

The Orca v6 A1 and A2 models allow the connection of additional PO<sub>2</sub> monitors or dive computers, to serve as independent means to monitor the gas mixture, and the optional 4<sup>th</sup> cell acts as an independent means of measurement. The manual addition valves are provided so that the diver can easily check the readings of the sensors at the same time as adding fresh gas.

#### 5.1.2. Automatic Oxygen Control

If the measured oxygen level, or partial pressure of oxygen ( $PO_2$ ) is below the desired level (or Setpoint), the Electronics Head injects pulses of oxygen until the desired level is restored. The further the measured oxygen level is below the setpoint the greater the rate of injection.

If the measured  $PO_2$  is above the Setpoint, the system will stop injecting gas until the user consumes enough oxygen for the  $PO_2$  to fall back below the setpoint.

---

**Note: The Setpoint may be selected either automatically by the module, based on depth and phase of the dive, or manually by the diver.**

---

#### 5.1.2.1. Automatic Oxygen Control: Variable Setpoint

The Orca v6 Electronic Head has an automatic function to adjust the oxygen level in the breathing mixture based on depth and the phase of the dive.

The objective is a balance between reducing risk of hypoxia and hyperoxia, reducing decompression obligation, and minimising interference with the user's buoyancy control.

The behaviour of the system is governed by the settings for:

- Surface Fraction
- Dive Setpoint
- Ascent Setpoints (if activated)

With the most basic settings (Surface Fraction and Dive Setpoint), the target oxygen level varies as follows:

- At the surface, and in shallow depths, the target is the Surface Fraction multiplied by the ambient pressure. The standard value is an  $FO_2$  of 0.6, or 60%  $O_2$ . This gives a  $PO_2$  of 0.6 at the surface, giving a low risk of hypoxia in shallow water (as the drop in lung volume would be obvious).
- As the user descends, the  $FO_2$  remains at 60%, and the  $PO_2$  is allowed to rise proportionally with pressure. This means that maintenance of the  $PO_2$  is not affected by changes in depth, so the system does not fight the user's buoyancy control to maintain  $PO_2$  (section 1 of the following graph).
- Beyond a certain depth (dotted line below) the  $PO_2$  rises to reach the Dive Setpoint. This is typically set at 1.2. The Unit will now maintain a constant  $PO_2$  as the diver goes deeper. Any further descents will now not cause changes in target  $PO_2$  (section 2 of the following graph).
- On ascent, the opposite occurs: as this transition depth is reached, the target once again swaps from constant  $PO_2$  to constant  $FO_2$ , ensuring a trouble-free final ascent (3). The user can still adjust oxygen levels manually using the Manual Add Valves.

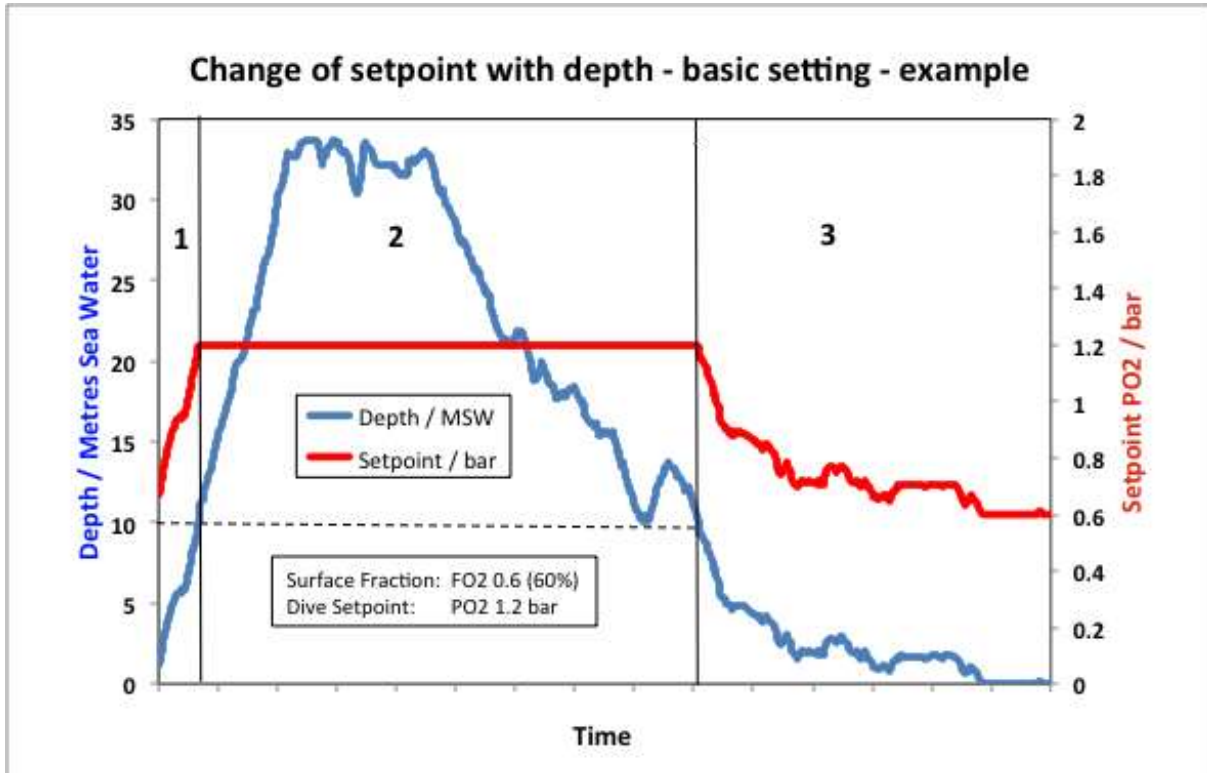

A further refinement is the addition of Ascent Setpoints, which may be useful for a diver performing longer dives, where lower oxygen levels are maintained to begin with, and during the deeper phases of the dive, to reduce oxygen toxicity, while higher levels will be given during ascent to accelerate decompression.

The system keeps track of the maximum depth reached, and changes over to a different, higher setpoint once the user, returning to the surface, has reached half maximum depth (a cut-off "start depth" is also used to prevent pointless fluctuations of setpoint during a shallow dive). Nearing the surface, a higher Ascent Fraction is also used to maximise decompression effectiveness while not destabilising buoyancy.

The process is shown in the following graph.

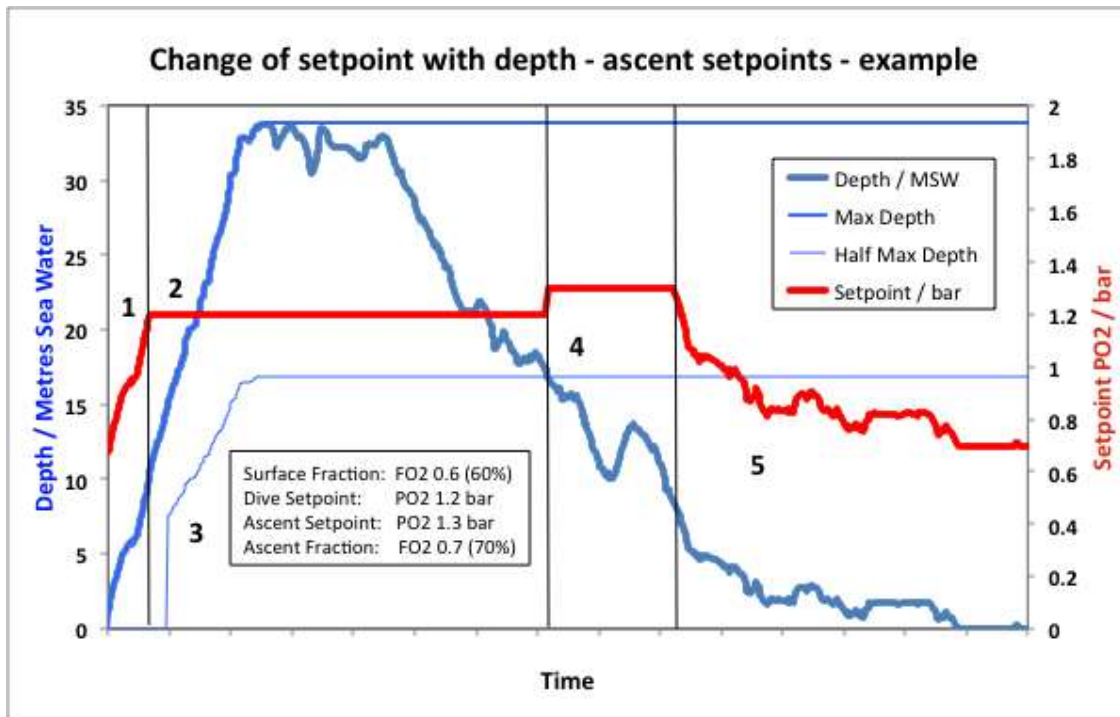

- At the surface, the target is the Surface Fraction. Here, set at a FO<sub>2</sub> of 60% as before.
- As the user descends, (section 1) the FO<sub>2</sub> remains at 60%, and the PO<sub>2</sub> is allowed to rise proportionally to pressure. Maintenance of O<sub>2</sub> level does not fight the user's buoyancy control (1).
- Beyond a certain depth, the PO<sub>2</sub> reaches the Dive Setpoint (2). Here this is set at 1.2 bar for reduced O<sub>2</sub> exposure. As before, the Unit will now maintain a constant PO<sub>2</sub>. Further descent causes no further change in target PO<sub>2</sub>.
- Once a certain activation depth is exceeded (here 15M) the system begins to track half maximum depth (3).
- At some point during the ascent, "Depth" equals half maximum depth (4). At this point, the "Dive Setpoint" is replaced with the higher "Ascent Setpoint" to accelerate decompression (4). (If the diver descends below half maximum depth again, the setpoint will revert to the original "Dive Setpoint.")
- As ascent continues, FO<sub>2</sub> eventually drops to the level of the second (higher) Surface Fraction (here, an FO<sub>2</sub> of 70%). As this transition depth is reached, the target once again swaps from constant PO<sub>2</sub> to constant FO<sub>2</sub>, ensuring a trouble-free final ascent (5). The user can still boost oxygen levels if desired by using the manual add button.

#### 5.1.2.2. Automatic Oxygen Control: Standard Settings

The Orca v6 is released with the following settings:

- Surface Fraction: 60%,
- Dive Setpoint 1.2 bar
- Ascent Setpoint 1.3 bar
- Ascent Fraction 70%

#### 5.1.2.3. Automatic Oxygen Control: Manual Setpoint



It is possible to perform dives in fully automatic mode, but in some circumstances, it is desirable to change the setpoint manually. Such circumstances include:

- **Before a rapid descent**  
Selecting a low setpoint will prevent the oxygen level spiking too high during rapid compression.
- **While checking the sensors underwater**  
While checking the sensors with a diluent flush, selecting a low setpoint will prevent the system trying to inject oxygen to correct the perceived problem.
- **If there is any doubt about the sensor's performance**  
If there is any concern that the sensors might be "maxed" leading to inappropriate oxygen injection, a low setpoint can be selected, acting as a "parachute" while the user injects oxygen manually at their discretion.
- **During decompression**  
If facing a lengthy final decompression stop, selecting a high setpoint can increase the concentration gradient to rid the user of inert gases.

Accordingly, Screen #3 (see Diving and Surface Screens Available above) enables the diver to choose the Setpoint. The Low, High and current Automatic Setpoints are shown. Pressing the left button selects a setpoint, then pressing the right button confirms the decision and returns the diver to the Three Sensors Screen (Screen #2) where they can see the effect of their decision. "High" cannot be selected unless there is sufficient depth.



Figure 1: Unit in Automatic mode



Figure 2: Left button press -> CHANGE

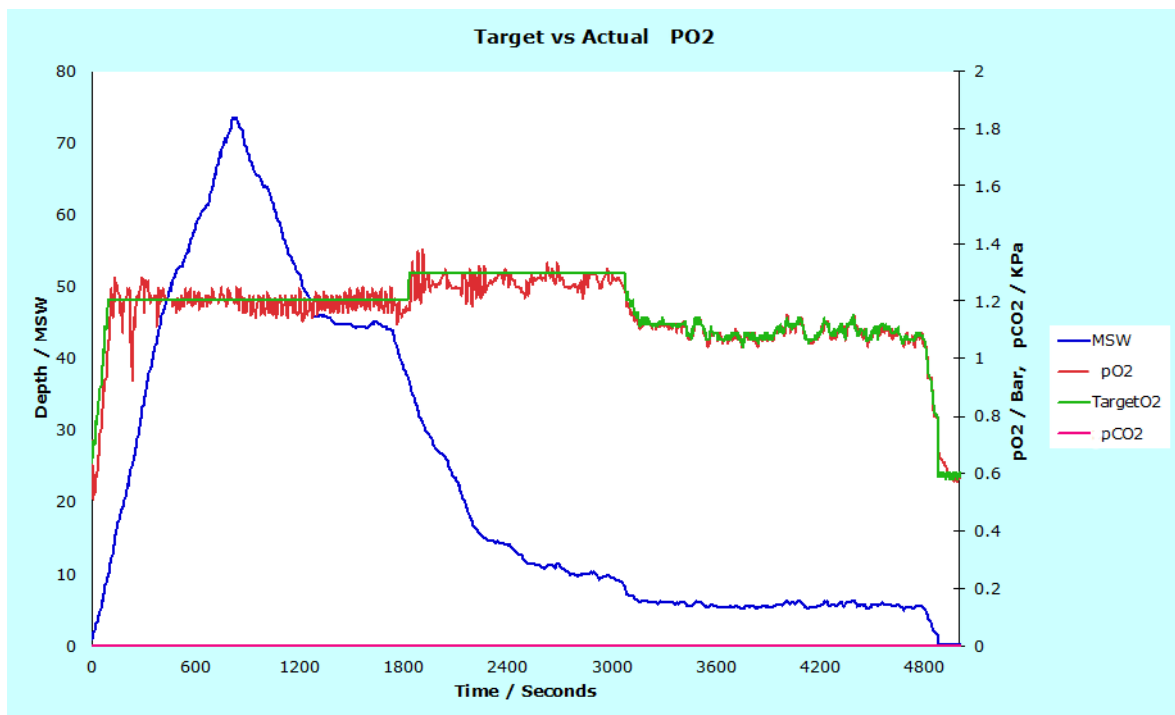

Figure 3: Right button press to confirm – low setpoint selected

#### 5.1.2.4. Automatic Oxygen Control: Variable Injection Rate

To reduce “overshooting” of the Setpoint target, the injection rate varies with distance of the measured oxygen level from the setpoint. If the measured oxygen level is far from the setpoint, the oxygen valve is fully open. As the measured value approaches the setpoint, the injection pulses become shorter.

Combining the two systems – variable target and variable injection rate – allows good control of the oxygen level during the dive. During rapid changes of depth and heavy activity, larger variations around the Setpoint will be seen, while with constant depth and gentle activity, smaller variations occur.



#### 5.1.2.5. Automatic Oxygen Control: Diver Awareness

As the Orca v6 Electronics Head is directly behind the diver’s head, it is possible to hear this variation in injection pattern while diving.

---

**Note: Normally, the Unit will spend a few seconds just above the Setpoint (no noise) and then will give a series of short bursts of oxygen, followed by another period of quiet.**

---

Rapid changes in depth will cause more obvious controller activity.

---

**Note: Extended periods of injection or no injection may highlight some system issue – for instance, leakage of one or other gas into the breathing loop - and should be investigated.**

---

Regardless of the automatic oxygen control, the user should always pay close attention to the PO<sub>2</sub> displayed on their handset screen, and the condition of their three sensors and should make sure they are able to reach and operate the manual controls for oxygen and diluent.

---

**Note: A 4th Oxygen Sensor, if fitted, can be monitored from your offboard computer.**

---

## 5.2. Dive Preparation

Having worked through the Pre-Dive Preparation and associated checks, you should have a fully assembled unit ready to dive, with counterlungs adjusted to fit your own breathing volume. You will need to perform the following to get ready to enter the water.

The following information is replicated in a concise form on a waterproof checklist supplied with your Orca v6. It should again be emphasised that this is not a substitute for training.

### 5.2.1. Initial checks

Make sure to confirm the following before putting on the unit:

- Gases are analysed
- Electronics are calibrated
- All hoses are connected
- All cables are connected, or unused ports capped
- Internal weights are in.

The nature of these checks makes it advisable to perform them before doing anything else. All further checks are devised so that if necessary, they can be performed while already wearing the unit.

### 5.2.2. Systems checks

The subsystems should have already been checked during assembly and initial preparation however the following tests can easily be done to proceed with confidence:

- Loop Test:
  - Make sure the DSV works. Check the directionality of the hoses by grabbing them with your hands and feeling resistance in the appropriate hoses during inhalation and exhalation.
- Positive Test:
  - Breathe into the unit until you hit the maximum. Pull the OPDV cord, confirming that (a) you can find it and (b) it releases gas.
- Negative Test:

- Turn off diluent. Extract all gas from the unit by breathing out through the nose. Confirm you can pull negative pressure. Pull OPDV cord to confirm no gas can enter the unit and negative pressure is maintained.
- Correct Volume:
  - Ensure you can hit the “top” and “bottom” of the lungs with deep breaths.
- High Pressure Systems Check:
  - Open all your cylinders and check that you have sufficient gas.
- Low Pressure Systems Check:
  - Confirm wing, bailouts, O<sub>2</sub> and Diluent MAVs and the ADV are functional.

### 5.2.3. Starting the electronics

When you turn on the electronics The system’s own INTERNAL CHECKLIST also asks the user the following questions:

- Sensor calibration?
- Sensors checked?
- Cylinders full?
- Scrubber OK?

---

**Note: It is important to note that these checklists are the duty of YOU, THE USER to follow. YOU must check these aspects, which are NOT under automatic control. See Troubleshooting for any problems that arise.**

---

### 5.2.4. Pre breathing with a Standard Loop

For the Standard Mouthpiece, with the electronics turned on and counterlungs sized, put the mouthpiece in and switch the DSV to the ON position, pre breathe the Unit for at least 3 minutes.

During this time check the following:

- All Oxygen Sensors are functional and responsive.
- The setpoint of 0.6 is maintained.
- CO<sub>2</sub> is scrubbed and is either at zero or rapidly reduced to zero.
- Check the Manual Add Valves and confirm sensors respond.
- The system is OK, with a green light, and there are no system errors.
- The Diver is OK: Easy to breathe and all feels good.

### 5.2.5. Hardware Checks

At this stage you can attach your heavier equipment and make sure your harness is correctly adjusted. As a guideline, you should make sure of the following:

- Any removable weights are attached and accessible.
- Bailout cylinders are attached and accessible and contain adequate gas.
- Your drysuit (if wearing one) is connected.

- Any other tools and equipment for the dive are ready.
- Your harness is clipped and tightened, and the releases are accessible.

### 5.2.6. Buddy Checks

You should now be ready to dive. It is important to confirm that your buddy understands the basics of how your equipment works before you enter the water.

- DSV operation
  - This is crucial should they need to assist you. Explain that they must close the DSV to \*their right\* if they have to remove it from your mouth on the surface.
- Understanding of displays:
  - at the very least, green, red-flashing, red solid.
- Buoyancy, weights and releases
  - For both divers
- Cross check of bailouts: ensure everyone knows which gas is which.
- Don't forget the basics: masks, fins, suits closed.
- Make sure any other procedures (such as initial bubble checks) are clear.

## 5.3. Entering the water

Entering the water should be done in accordance with your dive training, ensuring buoyancy and a breathable supply of gas.

Once in the water it is important to tighten the harness straps to ensure the Orca v6 is held close to the back for minimum work of breathing.

---

**Warning:** The mouthpiece should never be left in the ON position in the water when not in the user's mouth, or the rebreather may fill with water.



**The user must not try to inhale from a mouthpiece in the OFF position underwater as this will result in breathing in water!**

---

It is recommended to work with your buddy to perform a bubble check after entry, and to make sure at all times to rigorously monitor your PO<sub>2</sub>.

## 5.4. Descending

Buoyancy control is fundamental in diving and you must follow your training.

If wearing a drysuit you will have buoyancy in that, your Wing BCD, the breathing loop of the rebreather and in your own lungs. Following your training dump gas from your BCD and suit first.

The ADV will add gas to the loop during descent. You may also add diluent using your Manual Add Valve. Be sure to watch your PO<sub>2</sub> during any change of depth.

## 5.5. Buoyancy control

Unlike open circuit diving, buoyancy on the rebreather is not affected by breathing in and out. This means that once the gas mixture has stabilised, extremely steady buoyancy can be achieved. You must allow time for the setpoint to be reached before paying attention to fine-tuning of buoyancy. If wearing a drysuit, it is best to run this at minimum volume, ensure your breathing volume is correct and then make any compensations with the BCD. During the initial dives, you can then determine if you are over- or under- weighted and make corrections accordingly.

### 5.5.1. Venting gas from the system with the Standard Loop.

This may be done either through the nose, the corner of the mouth, or the OPDV on the exhale counterlung. To maintain buoyancy if rising with full lungs, exhale fully and then dump the remaining gas.

## 5.6. Ascending

During ascent you must control your counterlung volume as well as BCD and suit volume. Make sure you always have adequate volume to breathe, and do not use your counterlung as a buoyancy device. Vent the other devices as necessary to maintain this and control ascent.

During ascent it will be necessary to release gas from the system. This may be done:

- 1) Through the mouth or nose: The most efficient method is to exhale fully into the system until further exhalation is not possible and then leak the remaining gas in your lungs out through your mouth or nose. This ensures the most oxygen depleted gas is removed from the system.
- 2) Through the Exhale Counterlung OPDV: Pull the toggle as necessary.

During the ascent, the system will typically attempt to maintain or even raise the  $PO_2$ .

To minimise wastage of gas and excess buoyancy, one trick is to keep ahead of the system: when you wish to ascend, vent a small amount of gas, then rise until you are once again neutrally buoyant. It is also possible to vent gas and inject oxygen manually to keep ahead of the controller and accelerate decompression.

For brief excursions in depth, i.e. to swim over some object, switching the setpoint to "LO" reduces any interference with buoyancy.

In shallow water, the variable setpoint eliminates interference between buoyancy control and setpoint maintenance. In the final ascent, it is easy to maintain decompression stops.

---

**Warning:** See alerts on the maintenance of your  $PO_2$  during an ascent as this can drop rapidly due to reduction in pressure.



---

Once on surface:

- 1) Put air in BCD,

- 2) **Exhale into system,**
- 3) **Close mouthpiece and remove from mouth.**

## 5.7. Diluent Flush

A diluent flush is used to check the sensors and refresh the gas in the system.

### 5.7.1. Diluent Flush with the standard loop

A diluent flush is performed by injecting diluent using the diluent MAV while ejecting gas either through the corner of your mouth or through the Exhale Counterlung OPDV.

**To check the sensors** the best method is to release gas from the mouth as this causes gas to move forwards across the sensors.

**To purge the system of gas** it is best to eject gas through the OPDV with the left side 45 degrees up. In this case, exhale simultaneously to avoid an increase in buoyancy.

During the diluent flush it is best to breathe to cause the gas to circulate, causing full replacement of gas and movement of gas across the sensors.

## 5.8. Bailout procedure



**Warning:** The diver must always carry bailout gas. It must provide an adequate volume and safe breathing mix, to deliver the diver safely to the surface from all points during the dive. The diver shall receive details, training, and materials on selecting appropriate gases, volumes, and bailout equipment from their selected Lungfish Dive Systems Limited approved training agency/instructor.

---

If the user decides to switch to another breathing apparatus underwater, it is vital to close the DSV, before removing the mouthpiece, to prevent water entering the rebreather. Unless in an emergency bailout due to flooding or dangerous gas mix, it is also best to remove any gas from the rebreather by breathing in, ensuring the user is left with a lungful of gas and removing unwanted buoyancy.

## 5.9. Exiting the water

### 5.9.1. Standard Loop

On surfacing, it is important to exhale into the rebreather and then close the DSV before removing the Mouthpiece. This prevents water entering the rebreather and maintains buoyancy. It is recommended to be on the loop post-dive during any high-exertion activities, especially while re-entering the boat or ascending the shore, to avoid any risk of drowning or physiological shock of going from a low-exertion/high-oxygen environment to one with high exertion and low oxygen.

## 5.10. System Alarm Messages

The diver should remain continuously aware of the status of their rebreather by keeping the handset display where it may be seen, preferably attached to the forearm. In most swimming or working positions, this will keep it in clear sight.

If any of the main measurements (gas concentration, depth, duration) goes outside the acceptable range, the red light will flash, an alarm will sound, and a description of the problem will be shown in the bottom line of the display. Diving alert messages below. For instance, you will inevitably receive a "PO<sub>2</sub> Low" alarm whenever you turn the electronics on while disconnected from the Unit.

If an issue is acknowledged by pressing the left button, the alarm will cease for a short interval (1 minute underwater, 3 minutes on land) while the light will remain a solid red. **The problem value itself will then FLASH.**

---

**Note: The result of this is that even in a "mask off" or otherwise visually-compromised situation, the user, recalling the position of the different readings, may still identify and address a problem.**

---

As soon as values are restored to an acceptable level, the light will return to being green. Multiple issues may flash; a new issue will result in a renewed sounding of the alarm (so one problem does not "hide" another). As soon as the most severe problem is acknowledged, the alarm will sound for the next.

---

**Warning:** **These alarm messages relate to the functionality of the system itself. THESE ARE NOT USUALLY FIXABLE DURING THE DIVE, MUST BE TAKEN SERIOUSLY, and USUALLY REQUIRE THE DIVE TO BE ABORTED**



### 5.10.1. Oxygen sensors have failed

<p><b>ALARM TEXT:</b></p>	
<p><b>MEANING &amp; CAUSES:</b></p>	<p>One or more of the oxygen sensors have failed. Failed sensors are indicated by a cross on the "Three Sensors" screen.</p> <p>Criteria for failure are:</p> <ul style="list-style-type: none"> <li>• Below a certain level (burned out, damaged or disconnected)</li> <li>• Above a certain level (electrical fault)</li> <li>• Impossible (PO<sub>2</sub> &gt; total pressure).</li> </ul>
<p><b>ACTION TO TAKE DURING DIVE:</b></p>	<p><b>Diluent Flush.</b></p> <p>The system will run on the remaining sensor(s); but such a failure may indicate some underlying problem. Perform a diluent flush to check if remaining sensors</p>



	are credible. Either bail out, or if trained, be prepared to operate manually. Do not dive again until failed sensors have been replaced.
CODE ON DIVE LOG:	O21 / O22 / O23 depending on failed sensor.

### 5.10.2. O<sub>2</sub> sensors are beginning to disagree

ALARM TEXT:	
MEANING:	The O <sub>2</sub> sensors are beginning to disagree (usually set as a persistent deviation of 0.1 Bar) while not showing any definite malfunction.
CAUSES:	<ul style="list-style-type: none"> <li>• <b>Lack of Gas Flow before use:</b> This alarm is common on the surface if the Unit has been turned on but is not being breathed, as without circulation the O<sub>2</sub> will gradually diffuse across the faces of the sensors, leading to different readings. In this circumstance, simply breathe from the Unit and see if the readings align.</li> <li>• <b>Condensation:</b> Minor deviations on O<sub>2</sub> reading are often caused by the presence of condensation on the faces of the sensors. This usually results from repeated fast ascents or leaving the system to cool down with the head attached and the electronics turned off. Occasional checks of the three sensors may reveal this situation and a diluent flush will give an idea of sensor performance as well as expose the sensors to dry gas.</li> <li>• <b>Poor Calibration or lack of calibration:</b> New sensors will always give wrong readings until calibrated and are therefore likely to deviate. If sensors have been calibrated in air but not in O<sub>2</sub>, the higher the oxygen level, the worse the deviation.</li> <li>• <b>Current Limiting:</b> A sensor may be "burning out" and starting to under-read short of the level required for an elimination.</li> <li>• Actual damage or malfunction short of Elimination level: See "O<sub>2</sub> Sensor Failure" above.</li> </ul>
ACTION TO TAKE DURING DIVE:	<ul style="list-style-type: none"> <li>• Determine if safe to continue. Flush with diluent, to simultaneously check sensors and ensure a breathable gas mix. Observe readings of separate O<sub>2</sub> sensors. If none are believable, this indicates a more severe problem.</li> <li>• Bail out or control Unit manually if necessary.</li> <li>• <b>Reduce Setpoint to "LO" target:</b> This reduces the risk of hyperoxia due to malfunctioning sensors and allows the Unit to continue providing basic life support</li> <li>• Proceed with caution and begin ascent.</li> <li>• Make sure any problem is fixed before next dive.</li> </ul>
NOTES:	<b>Deviation sufficient to trigger this alarm underwater should always be taken seriously</b> , and potentially flagging up a more serious issue, even that

	the entire sensor area is flooded (in which case the sensors may diverge, and all will be "wrong" during a diluent flush). Accurate oxygen readings are vital to safe closed-circuit diving. The Orca v6 electronics make it easy to calibrate the cells and to check them under pressure so that this scenario is highly unlikely.
CODE ON DIVE LOG:	SpW "Spread Warning."

### 5.10.3. O<sub>2</sub> sensors disagree by more than 0.2 Bar

ALARM TEXT:	
MEANING:	<p>The O<sub>2</sub> sensors disagree by more than 0.2 Bar while showing no detectable fault.</p> <p><b>This is potentially a dangerous situation as it means your life-support system is unlikely to be able to supply you the correct level of oxygen. If the sensors are this deviant, they might well all be wrong.</b></p> <p>The message "Bail Out" is shown underwater, and the message "Do Not Dive" is shown on the surface.</p>
CAUSES:	<p><b>BAIL OUT!</b></p> <p>This alarm indicates actual failure of the sensors or the entire sensor head. If a sensor has failed altogether the alert may disappear when the controller eliminates the faulty sensor. However, until that point, all the sensor readings should be considered suspect.</p>
ACTION TO TAKE DURING DIVE:	<p><b>BAIL OUT!</b></p> <p><b>If this alarm is shown, the system can no longer be relied upon to keep you alive.</b> Flush with diluent to assess situation. A total system flood may cause a situation in which none of the sensors read correctly. Make sure any problem is fixed before next dive</p>
NOTES	
CODE ON DIVE LOG:	BaO

### 5.10.4. Calibration Failure

<p><b>ALARM TEXT:</b></p>	
<p><b>MEANING:</b></p>	<p>One or more of the sensors has failed calibration.</p>
<p><b>CAUSES:</b></p>	<ol style="list-style-type: none"> <li>1. One or more Sensors do not produce enough voltage in the gas used for calibration (air or oxygen) to be deemed viable (less than 80% nominal).</li> <li>2. The gas being used to calibrate at "100%" is not in fact oxygen.</li> </ol>
<p><b>ACTION TO TAKE</b></p>	<p>Message not possible during dive as calibration not allowed. Verify calibration gases are correct. If so, replace any failing sensors.</p>
<p><b>CODE ON DIVE LOG:</b></p>	<p>O2C1, O2C2, O2C3 depending on failed sensor</p>

### 5.10.5. One of the batteries is low

<p><b>ALARM TEXT:</b></p>	
<p><b>MEANING:</b></p>	<p>One or other of the batteries is low (&lt;3.7V)</p>
<p><b>ACTION TO TAKE DURING DIVE:</b></p>	<p>You have about an hour's battery life remaining after you first see this message. Begin to head back to the surface. Check the Battery Voltages screen and Time Remaining. CPU and Display will continue to operate if Valve battery is flat, allowing manual operation. Make sure to charge batteries before you dive again, or the system may stop underwater or present a Date Error or Handset Communications Failure.</p>
<p><b>CODE ON DIVE LOG:</b></p>	<p>BD or BV: <b>D</b>igital Signal Processor <b>B</b>attery or <b>V</b>alve <b>B</b>attery Low</p>

**5.10.6. Depth sensor has failed**

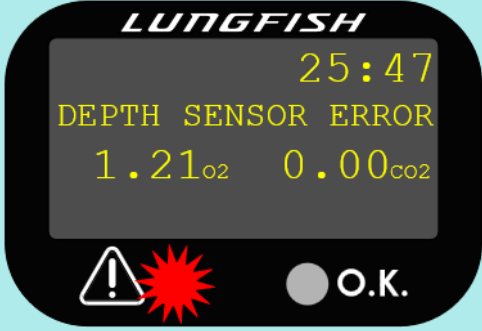
<p><b>ALARM TEXT:</b></p>	
<p><b>MEANING:</b></p>	<p>The depth sensor has failed.</p>
<p><b>ACTION TO TAKE DURING DIVE:</b></p>	<p>Keep a close eye on PO<sub>2</sub> as the system will now only maintain a basic oxygen setpoint and <b>will no longer correctly perform other functions including automatic setpoint control and accurate measurement of CO<sub>2</sub></b>. Control manually (if necessary) for your decompression.                  Prepare to abort dive.                  The system will itself attempt to re-initialise the depth sensor.  <b>This may indicate actual damage or disconnection of the depth sensor, and the need for repair before any further diving.</b></p>
<p><b>NOTE:</b></p>	<p>If this occurs during a dive (at pressure), the system will be stuck in Dive Mode and refuse to shut down. This is intentional, so that you cannot accidentally deactivate your life support system while in use. Once back on land, disconnect the handset (wash connector in fresh water first), wait a minute, and plug back in. This will cause the system to reboot, after which Shut Down will once again be available as an option.</p>
<p><b>CODE ON DIVE LOG:</b></p>	<p>DErr</p>

**5.10.7. Any error in the Sensor Head**

<p><b>ALARM TEXT:</b></p>	
<p><b>MEANING:</b></p>	<p>Any error in the sensor unit, usually causing the main system to temporarily disconnect the sensor head before powering up anything that still works. Oxygen sensor readings are "passive" and will not be compromised.</p>
<p><b>CAUSES:</b></p>	<p>This alarm will be triggered if the sensor head draws too much current, causing the supply voltage to drop and the system to power down the offending component. This function prevents a short – circuit causing damage or interfering with the rest of the system (i.e., the crucial oxygen readings), maintaining as much functionality as possible.</p>

ACTION TO TAKE DURING DIVE:	<b>IMMEDIATE DILUENT FLUSH.</b> Keep a close eye on all readouts if anything is still displayed on the screen (usually with this alarm, either the CO <sub>2</sub> sensor or depth sensor or both will be powered down). Check sensors by manual gas injection. Prepare to abort dive. <b>If this happens underwater, the problem should be investigated and rectified before any further diving.</b>
NOTE:	<b>In rare cases, pulling out the power cable while charging a Unit with insufficiently charged batteries can cause a sufficient voltage swing to trigger the alarm.</b> Restarting the Unit will rectify the situation. There is no equivalent circumstance underwater.
CODE ON DIVE LOG:	HE

### 5.10.8. Handset cannot communicate

ALARM TEXT:	
MEANING:	The handset cannot communicate with main control Unit. This could either be due to actual damage, very low battery charge (in which case the handset will run but the main Unit may not), or a faulty connection. <b>Note the presence of BLUE LIGHTS</b> The system will usually attempt to re-initialise itself.
ACTION TO TAKE DURING DIVE:	<ol style="list-style-type: none"> <li>1. If you have no other means of reading PO<sub>2</sub>, <b>BAIL OUT.</b></li> <li>2. Check if your handset connection has come unscrewed, and if so, do it back up. If not, at the very least inject diluent or switch to your bailout.</li> <li>3. If you can reach, or communicate with your buddy, check if the connection is loose at the other end and if so, do it back up.</li> <li>4. See if the cable has become crushed or damaged in some way and if this can be rectified.</li> </ol> <p>Without any form of display, you should <b>BAIL OUT</b>. Even if you have a HUD as a backup display and can hear the solenoid working, it would be extremely unwise to continue.</p> <p>You may continue IF you are equipped with a separate secondary display reading from the independent 4<sup>th</sup> sensor, or the isolator system.</p>
NOTE:	This message may be seen "harmlessly" during various surface operations such as reprogramming and log downloads, where the main processor is occupied with another task which prevents it talking to the handset. This is normal and does not indicate a malfunction.
CODE ON DIVE LOG:	NA4

**5.10.9. Date error**

This alarm is encountered, and can be fixed, on the surface.

<p><b>ALARM TEXT:</b></p>	
<p><b>MEANING:</b></p>	<p>The system does not know the date and time.</p>
<p><b>CAUSES:</b></p>	<p>Usually due to letting the batteries run completely flat.</p>
<p><b>ACTION TO TAKE:</b></p>	<p>This does not affect system performance but may result in incorrect dates being applied to dive logs in the memory (they will still be recorded in sequential order) and a persistent alarm and red light. Reset with correct date before you go diving.</p>
<p><b>CODE ON DIVE LOG:</b></p>	<p>SE</p>

**5.10.10. Shutdown Screen**

<p><b>ALARM TEXT:</b></p>	
<p><b>MEANING:</b></p>	<p>(First image) This message is the screen that allows the user to shut the Unit down. (Second image) Prompt to confirm shutdown.</p>
<p><b>ACTION TO TAKE:</b></p>	<p>They are only available on the surface, or if the depth sensor has failed and the unit has been reset underwater. Action: Confirm or reject the shutdown. Confirmation must occur within 3 seconds.</p>
<p><b>NOTE:</b></p>	<p>Not available underwater. By registering the Shutdown as an alarm, it warns the user in case they are at risk of turning the Unit off by accident, and it also causes the handset to revert to the Default Screen if they do not confirm the Shutdown within 3 seconds. Both serve to prevent accidental shutdowns. Shutdowns and attempted shutdowns (not confirmed within 3 seconds) are both recorded in the log.</p>
<p><b>CODE ON DIVE LOG:</b></p>	<p>NA7</p>

## 5.11. Diving alert messages

Diving alerts and alarms relate to deviations from acceptable limits of depth, dive time, or gas concentration.

If any of these measurements go outside the acceptable range, the red light will flash, an alarm will sound, and a description of the problem will be shown in the bottom line of the display.

If the issue is then acknowledged by pressing the buttons, the alarm will cease for a short interval, while **the light will remain a solid red**. The problem value itself will then **FLASH**.

As soon as values are restored to an acceptable level, the light will return to **green**.

---

**Note: For the sake of the colour-blind, the green light is provided with an "OK" symbol and the red with an exclamation mark.**

---

Multiple issues may flash; a new issue will result in a renewed sounding of the alarm (so one problem does not "hide" another). As soon as the most severe problem is acknowledged, the alarm will sound for the next.

The alarms, and immediate actions to take on seeing them, are listed below. Further actions to understand and solve any problem are discussed in more detail in Troubleshooting below.

### 5.11.1. *PO<sub>2</sub> too low (not necessarily at alarm level)*

If the oxygen level is dangerously low (<0.3), BAIL OUT.

Press oxygen MAV button immediately. If this does not work, make sure oxygen cylinder is open and try again. Then check the three sensor readings (screen #2) to verify values are moving. Observe any change in cell readings. If a 4th Oxygen Sensor is fitted check this on your offboard computer.

In general:

Press oxygen MAV. The PO<sub>2</sub> should climb to required level.

If no gas enters - make sure Oxygen cylinder valve is open. Check Oxygen Pressure Gauge.

If the oxygen MAV adds gas, but does not significantly increase PO<sub>2</sub>, you either have diluent in your Oxygen Cylinder, or a sensor problem. Bail out and diluent flush to check sensors. Return to surface if necessary.

### 5.11.2. *PO<sub>2</sub> persistently falling despite manual injections*

If you feel that you persistently have too little gas to breathe, or are sinking:

This may indicate a failure of automatic O<sub>2</sub> injection. Can you hear gas being injected? Diluent flush to check cells. Continue to operate manually or bail out. Prepare to return to the surface.

If you feel that you persistently have too much gas and cannot exhale:

This indicates excess gas entering the system. Make sure there is no diluent leak: turn off diluent cylinder valve and see if needle on gauge moves (be aware you may need to turn it on again in a bailout scenario or during further descent). The Manual Add Valve can also be disconnected separately.

If this has no effect (and the problem manifests itself early in the dive or even on the surface) this suggests that you may have the wrong gas in the oxygen supply (this should be analysed before diving) or faulty (maxed) or mis-calibrated sensors.

Check sensors, abort the dive and return to the surface.

### 5.11.3. Oxygen level is significantly below desired level

<p><b>ALARM TEXT:</b></p>	
<p><b>MEANING:</b></p>	<p>Oxygen level is significantly below desired level (usually set as 0.5 on the surface or in shallow water, and any value below 0.7 once 5m is exceeded).</p>
<p><b>CAUSES:</b></p>	<ul style="list-style-type: none"> <li>• Just started: low-PO<sub>2</sub> air or diluent in system, not yet oxygenated.</li> <li>• O<sub>2</sub> supply exhausted or not switched on.</li> <li>• Gas other than oxygen in O<sub>2</sub> tank</li> <li>• Leakage of diluent into system (obvious for other reasons)</li> </ul>
<p><b>ACTION TO TAKE DURING DIVE:</b></p>	<p>If O<sub>2</sub> level is dangerously low (&lt;0.3), <b>BAIL OUT immediately.</b></p> <p>Then check:</p> <ul style="list-style-type: none"> <li>• Is O<sub>2</sub> turned on?</li> <li>• If so, is O<sub>2</sub> supply empty?</li> <li>• If not, does pressing the O<sub>2</sub> bypass / Manual Add Valve cause PO<sub>2</sub> to rise to a safe level? (Check 3-cell display)</li> </ul> <p>If a clear problem has been identified and solved,</p> <ul style="list-style-type: none"> <li>• Go back onto loop</li> <li>• Immediate diluent flush to flush Unit and check sensors</li> <li>• See if sensors correct &amp; controller responds by adding O<sub>2</sub></li> </ul> <p>Based on these tests you can determine the correct course of action:</p> <ul style="list-style-type: none"> <li>• No Oxygen or wrong gas in oxygen tank? Plumb in offboard supply, if possible, semi-closed operation using diluent, or bail out</li> <li>• Sensor fault? Bail out.</li> <li>• Failure of automatic controller (i.e., jammed solenoid): Manual PO<sub>2</sub> control using O<sub>2</sub> Manual Add Valve.</li> </ul>
<p><b>NOTES:</b></p>	<ul style="list-style-type: none"> <li>• The problem must be fixed by at least 10% to deactivate the alarm. So, for instance, on the surface the alarm level is activated at 0.5 bar, but the alarm will only disappear once the O<sub>2</sub> level has exceeded 0.55 bar. This ensures the problem has truly been solved.</li> </ul>



CODE ON DIVE LOG:	O2L
----------------------	-----

### 5.11.4. PO<sub>2</sub> persistently too high (even if not at alarm level)

Press the diluent MAV button (left side) - PO<sub>2</sub> should reduce. If not, assuming you are using an appropriate diluent, there is a sensor problem.

Check the three-sensor screen. Are sensors responsive?

### 5.11.5. PO<sub>2</sub> still too high

Inject diluent again.

Possibility of an oxygen leak into the system. Turn off oxygen cylinder valve. Check if the needle on the gauge moves. If so, something is leaking.

If PO<sub>2</sub> is persistently, dangerously high - a major leak beyond what can be kept in check by occasional diluent additions - the system can be controlled by turning oxygen cylinder valve on and off (feathering) - injecting oxygen when necessary to maintain setpoint.

A sensor check can be performed by purging the system with diluent (or oxygen if safe to do so - i.e., if in shallow water or bailed out); values should correspond to (depth + 10)/10 multiplied by diluent fraction.

Return to the surface when possible.

A minor leak will give a flow rate proportional to ambient pressure. If the high-PO<sub>2</sub> problem only manifests itself at depth, this is probably the situation, as at shallow depths the leak rate will be sub-metabolic. In this case, you may notice that as you ascend the problem disappears. In this circumstance, leave the oxygen turned on for safety during the remaining ascent.

On return to the surface: verify whether leakage is occurring through MAV (bubbles emerge from hose if put in water) or solenoid feed. If neither has an apparent leak, check and calibrate sensors.

### 5.11.6. Oxygen concentration is above maximum safe level

ALARM TEXT:	
MEANING:	Oxygen concentration has exceeded maximum safe level (i.e. 1.55 bar).
CAUSES:	<ul style="list-style-type: none"> <li>• Rapid descent</li> <li>• Accidental addition of oxygen at depth</li> <li>• Leakage in oxygen system (inc. small leaks only apparent at depth)</li> </ul>

	<ul style="list-style-type: none"> <li>High-FO<sub>2</sub> gas in diluent tank</li> </ul>
ACTION TO TAKE DURING DIVE:	<p><b>If on Descent:</b></p> <ul style="list-style-type: none"> <li>This alarm is likely to trigger at the bottom of your initial descent.</li> <li>Short exposure to O<sub>2</sub> levels just above this level are harmless and you should aim to see this alarm at least once during every dive to verify that your sensors work.</li> <li><b>Add diluent</b> and the level should reduce.</li> </ul> <p>Brief spikes due to pressing of O<sub>2</sub> Manual Add Valve:</p> <ul style="list-style-type: none"> <li>Stop pressing button, or shorten presses if controlling manually</li> <li>Add diluent (if necessary) to reduce PO<sub>2</sub></li> </ul> <p>Otherwise: <b>BAIL OUT</b>. Then:</p> <ul style="list-style-type: none"> <li>Shut oxygen valve (observe pressure drop on gauge)</li> <li>Go back on loop</li> <li>Inject Diluent</li> <li>Feather O<sub>2</sub> valve: if O<sub>2</sub> values continue to rise uncontrollably, feathering the valve may be used as a means of manual control. If it appears that the diluent has a high FO<sub>2</sub>, use of offboard gas or bailout may be necessary.</li> </ul>
NOTES:	<ul style="list-style-type: none"> <li>You can safely O<sub>2</sub>-flush the Unit during your last 6 metres of ascent to check this alarm, as well as accelerating your decompression.</li> <li>The problem must be fixed by at least 10% to deactivate the alarm. So the alarm will only disappear once the O<sub>2</sub> level has dropped significantly below the danger level. This ensures the problem has truly been solved.</li> </ul>
CODE ON DIVE LOG:	O2H

**Note: The Orca v6 1<sup>st</sup> stage regulators are adjusted to work with the Electronics Head Solenoid. Do not use alternative regulators as this may overpower the solenoid and lead to runaway O<sub>2</sub> injection.**

### 5.11.7. CO<sub>2</sub> high

The CO<sub>2</sub> monitor allows you to identify and cope with various scrubber failure situations. These include the following:

#### **Very high CO<sub>2</sub> level at beginning of dive or during setup:**

Have you connected the breathing hoses backwards, or made a mistake installing the one-way valves, reversing the flow direction? Do the one-way valves work at all? Verify by gripping hoses as you breathe.

Upside-down mouthpiece? Easy to diagnose.

Is there actually any scrubber material in the canister?

#### **Moderate, rising CO<sub>2</sub> level at beginning of dive:**

Scrubber is old or mis-packed. Return to surface.

#### **Sudden high CO<sub>2</sub> level for no obvious reason:**

Grip hoses to check one-way valves. If they have failed, this might also be associated with a low PO<sub>2</sub>.

Has the scrubber been flooded or otherwise compromised? See section below on water in the rebreather.

Purge with fresh gas, semi-closed or open-circuit bailout as necessary.

**CO<sub>2</sub> present following heavy exercise:**

Purge with fresh gases as appropriate for depth; reduce work rate. Problem should disappear.

If problem persists, replace loop contents, repeating when level becomes high enough to trigger alarm. Semi-closed or open-circuit bailout as necessary.

**CO<sub>2</sub> gradually increasing after a long time in the water:**

Natural depletion of scrubber over time. From first alarm, you should have at least 20 minutes of effective use left with moderate effort, more if relaxed.

Do not rule out the possibility of a flood. Purge with diluent, replace loop contents when level becomes high enough to trigger alarm.

**5.11.8. High CO<sub>2</sub> Alert**

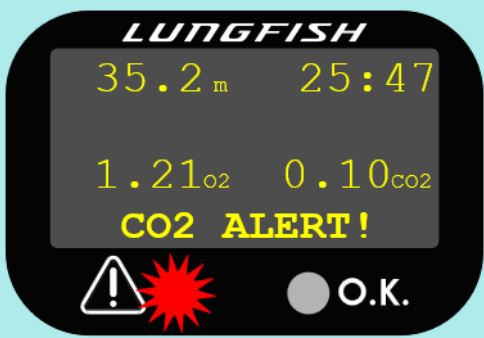
<p><b>ALARM TEXT:</b></p>	
<p><b>MEANING:</b></p>	<p>The partial pressure of CO<sub>2</sub> in the inhaled gas has exceeded 0.1 KPa.</p>
<p><b>CAUSES:</b></p>	<p>Scrubber material exhausted (Breakthrough)                  Scrubber flooded.                  Bypassing (insufficient or no material in scrubber).                  Scrubber too cold to work properly.</p>
<p><b>ACTION TO TAKE DURING DIVE:</b></p>	<p><b>Bail out.</b>                  Diluent flush loop and return to system with caution if CO<sub>2</sub> level decreases.                  In general: Begin your ascent. See if level reduces. Purging loop should reduce level. At moderate exercise rates a normal scrubber can usually be used for at least 20 minutes after seeing this alert. Do not descend further unless situation solved.</p>
<p><b>NOTE:</b></p>	<ul style="list-style-type: none"> <li>• While 0.1 KPa CO<sub>2</sub> is not in itself dangerous, it can indicate a rapidly deteriorating scrubber, and this warning should be taken seriously.</li> <li>• Unlike some sensors the Orca v6 CO<sub>2</sub> sensor does not have cross-sensitivity for water vapour. A CO<sub>2</sub> alert really indicates the presence of CO<sub>2</sub>. The only circumstance in which a bogus alert is shown is if the sensor is flooded with water and shorted out, in which case the entire system is probably full of water and the correct action is the same: to bail out.</li> </ul>

CODE ON DIVE LOG:	CW
-------------------	----

### 5.11.9. High CO<sub>2</sub> Alarm

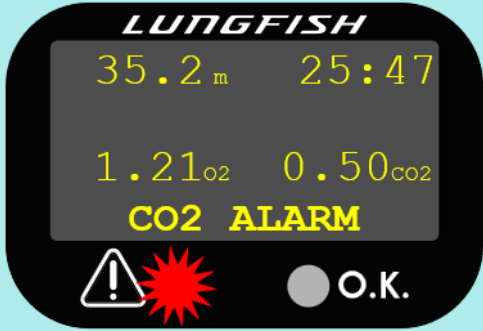
ALARM TEXT:	
MEANING:	The partial pressure of CO <sub>2</sub> in the inhaled gas has exceeded 0.5 KPa.
CAUSES:	Any of the reasons discussed above, but more serious.
ACTION TO TAKE DURING DIVE:	<p><b>BAIL OUT.</b></p> <p>This is a more serious CO<sub>2</sub> level, not to be tolerated especially in conjunction with a high PO<sub>2</sub>. You must bail out, flush the Unit with appropriate gas to purge out the CO<sub>2</sub>, and stay bailed out if this cannot keep the level down.</p> <p>If the scrubber has truly broken through, the CO<sub>2</sub> level may begin to rise exponentially beyond this point, so this warning must be taken extremely seriously as at higher CO<sub>2</sub> levels you may not be able to respond fast enough.</p> <p><b>HIGH CO<sub>2</sub> LEVELS ARE PARTICULARLY HAZARDOUS IN CONJUNCTION WITH DEPTH AND HIGH PO<sub>2</sub>.</b></p> <p>What can be tolerated on the surface or in the shallows should not be risked at depth.</p>
NOTE:	Unlike some sensors the Orca v6 CO <sub>2</sub> sensor does not have cross-sensitivity for water vapour. A CO <sub>2</sub> alarm really indicates the presence of CO <sub>2</sub> . The only circumstance in which a bogus alarm is shown is if the sensor is flooded with water and shorted out, in which case the entire system is probably full of water and the correct action is the same: <b>BAIL OUT.</b>
CODE ON DIVE LOG:	CA

**Warning:**



1. **If you have the slightest doubt about the situation, or your ability to cope with it, bail out.**
2. **Never continue descending if you have CO<sub>2</sub> issues. A harmless level in shallow water may become dangerous under pressure.**

### 5.11.10. Depth Alarm

ALARM TEXT:	
MEANING:	You have exceeded the user-defined dive depth limit.
ACTION TO TAKE DURING DIVE:	Ascend to stick to your dive plan. If alarm is inappropriate, ensure setting is correct before next dive.
CODE ON DIVE LOG:	HA ("height alarm").

### 5.11.11. Dive Time Limit

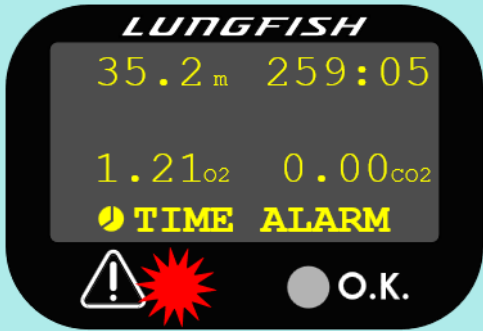
ALARM TEXT:	
MEANING:	You have exceeded a user-defined dive time limit.
ACTION TO TAKE DURING DIVE:	<p>Ascend and stick to your dive plan. If alarm is inappropriate, ensure setting is correct before next dive.</p> <p>When acknowledged, the light will return to be green and the alarm will not sound again for several minutes. This is because going over time is not intrinsically dangerous and so is not allowed to mask other issues.</p>
CODE ON DIVE LOG:	TA

## 5.12. Breathing volume management

### 5.12.1. Difficulty inhaling fully: inadequate gas volume

#### Check PO<sub>2</sub>:

If low, you are being given advance warning of inadequate oxygen supply.

If normal, you have just lost some gas somehow (through nose, mouth, mask clearing, etc).

Add gas as appropriate using manual add valves (diluent if deep, oxygen if shallow, or significantly below setpoint).

Check PO<sub>2</sub> again, using “three-sensor” view.

---

**Note: If the problem has been present for the entire dive – have you set the lung volume correctly?**

---

### 5.12.2. *Difficulty exhaling fully: excessive gas volume*

Are you descending or ascending? If so, see sections on this above.

**Otherwise:**

If the problem is transient – exhale as far as you can, then vent the remaining gas in your lungs through the side of your mouth or your nose.

If problem is persistent, check PO<sub>2</sub>. Is PO<sub>2</sub> above or below target? Can you hear the solenoid injecting or not?

If PO<sub>2</sub> is over setpoint and no injections occur, there may be a leak in the oxygen system.

If PO<sub>2</sub> is under setpoint, there may be a leak in the diluent system.

If necessary, the problem may be managed by turning the off and then feathering the respective cylinder valves. DO NOT FORGET YOU HAVE DONE THIS as you may need to open the cylinder valves again to provide manual-add gas, buoyancy, or bailout gas during ascent.

Another source of this problem (excessive gas volume) is exhalation through the nose. This might result in inhalation of diluent from the ADV, to replace the missing volume, after which the system will inject additional oxygen to bring the mix to setpoint. Exhale as far as possible, exhaust any residual gas in your lungs through the corner of your mouth, and then continue to breathe as normal.

## 5.13. Water in the rebreather

There are various means by which water can enter a rebreather. In order of severity, these are:

**Misconnection or failure of a part:** Easily avoided by doing positive and negative pressure checks before diving

---

**Warning:** **Misconnection or failure of a part is serious, as it is hard to fix during a dive. bail out, abort the dive, exit safely and address the issue in a safe location.**



---

**Entry of water through the Mouthpiece:** Either through dislodgement, improper shutoff operation or actual damage.

**Should be addressed.** Check DSV lever is properly orientated in the desired position.

---

**Note:** The most insidious source of flooding is damage to the Mouthpiece Bite itself, as this will not show up during the standard Pressure Check.

---

**Warning:** A failure of the Mouthpiece Bite itself will not be detected in the above procedure and this part must be visually inspected before the dive.



---

**Condensation formed inside the Orca v6:** This is unavoidable due to 100% humidity within system.

**Not Serious** if small quantities generated – usually only noticeable after the dive as fresh water found in the base of the scrubber and in the inhale lung.

Water in the Orca v6 is NOT indicated on the display but can be detected by the noise (gurgling from breathing hoses / backpack).

### 5.13.1. *Removal of Water from the Mouthpiece and Loop*

Small quantities of water near the mouthpiece (coughing noise on breathing out) can be ejected into the Counterlung by holding the hose down to the shoulder, rolling to the left and exhaling sharply, then briefly moving to a vertical position.

An alternative method to remove water from the breathing hoses is to close the Mouthpiece, remove it from your mouth, and raise the hoses above your head, while shaking them, again while briefly moving to a vertical position. You may switch to open-circuit during this procedure although it should be quick enough to do without. This should cause any water to fall to the bottom of the Exhale Counterlung (which is large to act as a water trap).

**This water must then be removed from the Exhale Counterlung as detailed below.**

### 5.13.2. *Purging water from the Exhale Counterlung*

Liquid in the counterlungs may be ejected by the following means.

- Locate the Exhale Counterlung OPDV Toggle (left side) and diluent Manual Add Valve.
- Roll left side down (a full 90° roll will enable removal of liquid from the scrubber but return to about 45° for the next step) and pitch about 10-20° head up.
- Exhale fully into the counterlung (to avoid extra buoyancy), and then close your mouth.
- Simultaneously pull the Exhale Counterlung OPDV Toggle and press the diluent Manual Add Valve until all water is ejected and gas (bubbles) can be heard emerging.

The procedure may also be performed while bailed out, which allows it to be done at leisure, but care must still be taken to exhale during the procedure to avoid excess buoyancy. If in shallow water, oxygen may also be used as the purge gas instead of diluent.

Now observe the displays carefully to ensure that oxygen levels are returning to normal and that CO<sub>2</sub> levels are not building up (indicating a spoiled scrubber).

---

**Warning:** **DO NOT ignore a build-up of water in the system**, as once the Exhale Counterlung is full, this will enter the scrubber and reduce or stop its function, also rendering the flooded water alkaline, and risking breathing in a hazardous "caustic cocktail.". It also reduces buoyancy.



Large quantities of water inside the system will be indicated by increased breathing resistance, and loud bubbling or gurgling noises.

The various water traps will temporarily prevent water from flowing through to the electronics and Inhale Counterlung, but eventually it may soak through, at which point you will risk the fluid entering your mouth. (A flooded scrubber is indicated by high breathing resistance and possible CO<sub>2</sub> alarms or alerts.) So, make sure that a flooded system is purged.

If this is not possible, bail out and return to the surface.

### 5.13.3. *A flooded rebreather*

---

**Warning:**



**If the rebreather is flooded you must bailout.**

---

### 5.13.4. *Post dive examination*

If you find fluid in your Orca v6 after the dive, it is worth finding out what it is. Pouring it out and checking the colour and pH, and assuming you have been regular with cleaning and maintenance, it may be worth cautiously tasting this liquid to determine what it might be.

**Clean fresh water in counterlungs:** Likely to be (harmless and inevitable) condensation, unless you are diving in clean fresh water. Check the counterlungs and OPDV.

**Salt water in Exhale Counterlung:** Most likely let in from mouthpiece, or if dirt and debris is fouling OPV. Check condition of mouthpiece, mouthpiece bite, counterlung and OPDV. Positive/negative pressure test.

**Dirty fresh water in Exhale Counterlung:** Some yellowish dribble is inevitable using the Standard Loop. Do not taste. Remember to clean and dry the Unit between dives. Sterilise the Unit as per cleaning instructions.

**Alkaline water in Exhale Counterlung:** Water has exited from the scrubber. Origin can only be from a flood followed by purging.

**Alkaline water in Inhale Counterlung:** Flood water has made its way through the rebreather. Examine seals for integrity and presence of dirt.

**Salt water in Inhale Counterlung:** Damage or misconnection, probably of the ADV or one of the MAVs. Check entire breathing loop for damage and positive / negative pressure test.



**Wash the counterlungs and hoses with clean water, sterilise if necessary, and leave to dry.**

## 6. Cleaning Post dive

---

If a diver is making multiple dives in one day on the same Orca v6 it is not necessary to wash and sterilise the Unit between dives.

If the Electronics Module is not removed between dives, it should be left switched on.

---

**Note: Be sure to verify battery charge before diving again if the Orca v6 is left switched on.**

---

### 6.1. Cleaning and disinfection of the Orca v6 after diving

- 1) After diving, making sure oxygen and diluent supplies are still turned on and the BCD and Counterlungs are inflated. Make sure the breathing loop is in the OFF position at this stage (DSV handle to the left, in surface mode) to avoid water entering the loop. Empty any water from the Exhale Counterlung using the OPDV.
- 2) Rinse the entire rebreather including the Outer Casing, BCD and Inflator Hose, cylinders and hose connections in fresh flowing cold or lukewarm tap water (less than 50 degrees Celsius). Take special care to wash the cylinder valves, first stages, power inflator and MAVs to avoid salt build-up.
- 3) Open the Outer Casing to expose the scrubber and Electronics Head. Remove any internal weights if present.
- 4) Rinse the weight pocket and the outside of the scrubber and head.
- 5) Ensure oxygen supply is pressurised. Wash oxygen hose connection to head. Dry this area with a soft cloth and disconnect hose while still pressurised.
- 6) Remove the Electronics Head (see Removal of Electronics above) and wipe off any condensation with a soft cloth. Put away for charging and storage in a dry place, out of direct sunlight.
- 7) Close the cylinder valves.
- 8) Press the MAV buttons to blow any liquid out of the MAV return hoses before removing the scrubber. This also serves to depressurise the gas supplies.
- 9) Remove the Scrubber. Check for any liquid by gently tipping it to drain. Replace white Scrubber Clip in scrubber to ensure it is not lost.

---

**Warning:** It is not advisable to turn the Unit upside-down with the electronics still attached, to avoid the risk of liquids falling onto the sensor area.



---

**For an Orca v6 Mouthpiece,** remove the Breathing Loop and the Counterlungs.

- 1) Drain any excess fluid from the hoses by compressing them in the vertical position with the open end down. Place the loop in a tub of fresh water at ambient temperature containing Chemgene™ at a dilution ratio of 1 part Chemgene™ HLD4H Surface Disinfectant to 100 parts water. Make sure there are no air bubbles trapped inside the breathing loop.

- 2) Drain any excess fluid out of the Counterlungs and immerse in the tub with the breathing loop, again making sure there are no air bubbles trapped inside the Counterlungs. All surfaces should be wet for a period of 10 minutes.
- 3) Remove the Loop and the Counterlungs from the tub and rinse thoroughly in cold fresh running tap water. Hang to drain.

For care and maintenance of the Breathing Hose O-rings see the relevant maintenance section below.

## 6.2. Cleaning and disinfection of the BCD after diving

- 1) With the BCD still inflated, drain any water into the side of the BCD with the OPDV. Orientate the Harness and BCD so that the BCD OPDV is at the lowest point and drain and water from the BCD. Repeat as necessary to empty the BCD bladder.
- 2) Always wash the BCD, including the inside of the bladder, in fresh water after every dive. Diving in chemically treated swimming pools could damage or discolour the fabric of the BCD. Fill the BCD one third full of fresh water through the inflator mouthpiece. Inflate fully, then rotate and shake, ensuring a complete internal rinse. Hold upside down and completely drain the water through the mouthpiece. Thoroughly rinse the outside of the BC with fresh water.
- 3) Place to dry out of direct sunlight in a well-ventilated place. Do not leave on the ground for extended periods of time.
- 4) Periodically flush the BCD with sanitizer solution (available in dive stores) or Steramine™ solution to kill any bacterial growth.

## 7. Care, User Maintenance and Servicing

---

**Warning:**

**The ORCA v6 requires yearly service inspections (maximum 12 months) or after 150 hours of usage, whichever occurs first.**

**Service inspections must be performed by a service technician certified by Lungfish Dive Systems or performed by the manufacturer.**

---

In addition to the below system maintenance, all O-rings should be checked for nicks, cuts and correct lubrication regularly, during regular component assembly and periodically, at the end of a week's diving and after a period of storage.

All user-serviceable parts and service kits are available from your instructor/dealer.

### 7.1. Breathing Loop

Post-dive, the entire loop assembly can be washed with fresh water, or sterilised by closing the DSV Lever, supporting the assembly in a U shape and filling with sterilising solution.

Washing in fresh water followed by removal of water by squeezing and hanging to dry is sufficient for daily maintenance.

Sterilisation is advised after prolonged use (sterilise at least weekly) and before any period of storage or when sharing the Unit between divers. Chemgene, diluted to the manufacturer's specification, is the recommended sterilising agent. See cleaning section.

---

**Warning: Cleaning solutions must be used as per user instructions provided by the manufacturers.**



After sterilisation, wash the DSV and Breathing Hoses with fresh water.

It is recommended to dry the hoses before storage.

Visually inspect the Breathing Hoses and Mouthpiece Bite for any damage.

#### 7.1.1. Maintenance of Breathing Hoses

To inspect the one-way valves, the hoses may be removed from the Mouthpiece by withdrawing the Locking Cords, and then pulling out the hoses by gripping the hose and the cuff inside close to the mouthpiece.

---

**Caution:**

**Do not simply pull on the hoses. This may result in damage.**

---

Minor leakage maybe caused by dirt or debris on the mushroom valves may be treated by washing. If valve removal or replacement is necessary, this may be done by removing the Herbie Clips and PVC Tape from the breathing hose to remove the valve

cake. Be careful not to cut the material of the hose, and to replace the PVC Tape (four wraps) and Herbie Clip (soaked for 24 hours or stored in water before fitting in original position, completely closed) when done. Herbie Clip Type T on the Mushroom Cage and Herbie Clip Type S on the Counterlung Connection (marked on the Herbie Clips).

---

**Warning:** **If you disassemble both hoses, be sure to reassemble the correct side of the DSV with the correct colour end fitting, Red exhale and Black inhale, or the gas flow around the Orca v6 may be reversed!**



---

To re-fit the entire hose to the mouthpiece, ensure the captive O-rings in the mouthpiece are intact and lubricated with SGM494 silicone grease, insert (this requires correct alignment and moderate force) and replace the locking cords. Ensure the correct hose is in the correct side, or the mouthpiece will be inverted when you try to connect the Breathing Loop to the Counterlungs.

The O-rings at the counterlung ends of the hoses may also be lubricated with silicone grease if operation is stiff. Damaged O-rings may be removed using a plastic O-ring pick.

### 7.1.2. Maintenance of Standard Mouthpiece

The DSV is designed to be simple and is easily dismantled for ongoing and annual servicing, checking or lubrication (if stiff). See component parts below, including Cages and one-way Mushroom Valves from the breathing hoses, below.

The mouthpiece assembly (including cages and one-way valves, if dismantled from the hoses) may be checked for integrity by breathing from it while in the "ON" position, and alternately covering the hose ports with the hands. If leakage is evident, cleaning or maintenance is required.

---

**Warning:** **If the Mouthpiece Bite is worn, damaged or cracked it must be replaced before diving.**



---

To dismantle, remove the Locking Cord from the underside of the DSV and remove the Breathing Hoses from the sides of the Mouthpiece Body as above. Note the captive O-rings inside the ports of the Mouthpiece. Check their presence and condition. Replace as necessary.

To remove the Top Cover, remove the Top Plate Bolts. To remove the DSV mechanism, turn the DSV Lever to the ON position (at the right from the diver's perspective) to avoid cutting the O-ring, and lift out.



1	Bolts (x4)	6	Locking cord (x2)
2	Top Cover	7	Mouthpiece body captive O-rings (x2)
3	Mouthpiece Core	8	Mouthpiece bite
4	Core O-rings (Upper and Lower)	9	Mouthpiece bite Cable Tie
5	Mouthpiece Body		

Before reassembly, inspect the parts, replace any damaged O-rings, and lubricate the O-rings and fill the cross-hole in the shutoff with food-safe silicone grease (SGM494).

Reinsert, again with the DSV lever to the right.

To remove the Mouthpiece Bite, the cable tie may be cut. Avoid using sharp tools to cut the cable tie if the Mouthpiece Bite is not being replaced. These could slip and cut the Mouthpiece Bite.

## 7.2. Maintenance of Counterlungs

### 7.2.1. Cleaning

It is recommended that the Counterlungs are washed internally and externally with fresh water after the day's diving, and are disinfected at least after every week's sustained use, or prior to storage.

Chemgene, diluted to the manufacturer's specification, is the recommended sterilising agent. After sterilisation, wash with fresh water and hang to dry. See Cleaning above.

---

**Warning:** Cleaning solutions must be used as per user instructions provided by the manufacturers.



### 7.2.2. Storage

The Orca v6 Counterlungs have a smooth lining completely flush with their connection ports, so are extremely easy to drain following cleaning.

Supporting the lungs in a vertical position with the breathing hose connectors pointing downwards will allow all liquid to drain out. The Counterlungs should be stored in a well-ventilated space free from dust and other contaminants to dry thoroughly before storage.

---

**Warning: A tumble dryer should not be used.**



**Protect from direct sunlight.**

---

### 7.2.3. Lubrication

Counterlung O-rings should be lubricated with Christolube (to avoid lubricating silicone O-rings with silicone grease).

### 7.2.4. Repair of leaks, water ingress

The Counterlungs are not user serviceable parts. If damaged, they should be returned for service and pressure testing, or replacement.

Water ingress may not mean the Counterlung has a defect, however. The most likely source of leaks are damaged O-rings or loose connectors.

Check the O-rings and sealing surfaces for defects, replace as necessary. Check the Mushroom Valve in the OPDV is in good order and seated correctly. Replace any of these, if necessary, with parts from the appropriate service kit.

ADV and OPDV connectors, if loose, may be retightened with specific tools that are supplied by Lungfish along with specific training.

## 7.3. Maintenance of the Oxygen and Diluent Systems

**Diluent Cylinders:** As supplied from the factory these are prepared ready for normal quality diving air, as is the cylinder valve. The inspection and hydrostatic testing regulations for this cylinder will vary from Country to Country. In the UK, the current requirements are for internal inspections every 2½ years with a hydrostatic test every 5 years.

**Oxygen Cylinders:** Supplied from the factory, these cylinders are oxygen clean. The legal requirement in the UK is for an internal inspection every 2½ years with hydrostatic testing every 5 years. Oxygen cylinders must be serviced, and oxygen cleaned every year.

Parts may be returned to LDS for service and testing.

The entire oxygen system should be dismantled and checked annually, fraying or damaged hoses should be replaced, O-rings checked and replaced, especially those that may be pressurised for extended durations.

After each dive, when washing down your equipment make sure to flush the MAV casings inside and out with fresh water.

If the MAV requires servicing it is recommended this is done by trained and competent persons.

On reassembly, it is important to use oxygen compatible O-rings and lubricants, Christo-Lube is recommended to be used in accordance with the manufacturer's instructions.

We recommend the following intervals for routine overhaul (including change of main O-rings, cleaning and re-lubrication):

Aggressive conditions (heavy use, high salinity, high temperature, frequent immersion / drying):	100 Dives
Normal conditions (Marine use, washed with fresh water after diving):	1 years

### 7.3.1. Maintenance of the Automatic Diluent Valve

The ADV is supplied from the factory correctly tuned and should not require maintenance outside the regular cycle. The following information is by way of precaution.

#### 7.3.1.1. Routine Care

The ADV (left installed on the Unit) should be washed in fresh water after diving, along with the rest of the Orca v6. The interior may also be washed with fresh water and should then be left to dry.

#### 7.3.1.2. Leakage of gas into loop

A continuously leaking ADV will cause a progressive increase in counterlung volume during a dive, and excessive oxygen injection to compensate for the diluent. It may be detected by a gradual depressurisation of the diluent system if the cylinder valve is closed. It may be confirmed by holding the outlet up to the ear while pressurised, or filling with water and looking for bubbles. It may be correctable by screwing the "crown" inwards slightly, preferably using an inline adjuster tool, to fine-tune while pressurised from the Unit's own diluent supply. This should be done by a trained SCUBA service technician. If this procedure does not work, consult a Lungfish service technician.

#### 7.3.1.3. Excessive gas addition

Excessive gas addition during a dive (but not continuous leakage) will also give unwanted loop volume and buoyancy, especially when head-down. This may be corrected by, using a hex key on the Cracking Pressure Adjuster opposite the gas inlet.

#### 7.3.1.4. Excessive cracking pressure / difficulty obtaining gas

This may be corrected by using a hex key in to loosen the Cracking Pressure Adjuster. Do this while the ADV is connected to the diluent supply. It should be possible to obtain gas from the ADV with a strong inward breath. Do this a small amount at a time, and do not make the addition excessively easy, to avoid excessive gas addition during the dive, or gas addition while inverted. The breath should not be effortless: being able to add gas without consciously triggering the valve would create a risk of hypoxia should there be



any problem with the oxygen system or electronics. If in any doubt, consult a service technician.

## 7.4. Care and maintenance of the Scrubber Canister

The Scrubber is made from a tough material but to ensure long life it should be protected from impacts and abrasion and stored dry and out of direct sunlight.

- Do not scratch sealing surfaces.
- Always purge MAVs and drain condensation after a dive.
- Do not store containing used scrubber material.
- After a period of diving visually check O-rings and clean main O-ring and groove, re-lubricate with Christolube before next use.
- Wash carefully after exposure to heavily chlorinated water to avoid discoloration.

## 7.5. Care and Maintenance of the Electronics Module

The following basic care guidelines apply:

- When possible, remove the electronics module after diving, to avoid condensation building up on the sensors as the system cools.
- Before removing the head, always keep the oxygen feed pressurised, and wash the Head and all its connections in fresh water and dry off before disconnecting the oxygen feed. This removes any chance of saltwater contaminating the Solenoid.
- Remove the entire module after diving, rather than disconnecting the cables.
- Keep the electronics module dry and keep it charged.
- Calibrate before the day's diving and use in-date sensors.

### 7.5.1. The Electronics Head

All **O-rings** on the head should be inspected regularly for defects, as should the sealing surfaces against which they match.

When storing the Electronics Head, wipe off excess grease from the Head Main O-ring and Oxygen Port O-rings before putting them in their box.

Check the Sensor Head, USB port and the 4<sup>th</sup> Sensor (if used) are clean and dry after diving. Remove the caps and visually inspect for water or other contaminants. Wick out any moisture with a soft absorbent cloth and leave to air dry. Check the O-rings for nicks, cuts and anything that may break the seal.

**The Silicone Boot**, shown in the image right, (1) in the Sensor Head is not fixed in position but held in place by its shape and texture. Though it is very flexible and quite resistant, if the Boot is torn or damaged, during the replacement of Oxygen Sensors (2) for example, it should be replaced.

If it is replaced, or when replacing Oxygen Sensors, great care should be taken not to touch the Pressure Sensor (3) located at the center of the Sensor Head. See the image below. The CO2 Sensor (4) should not be removed.

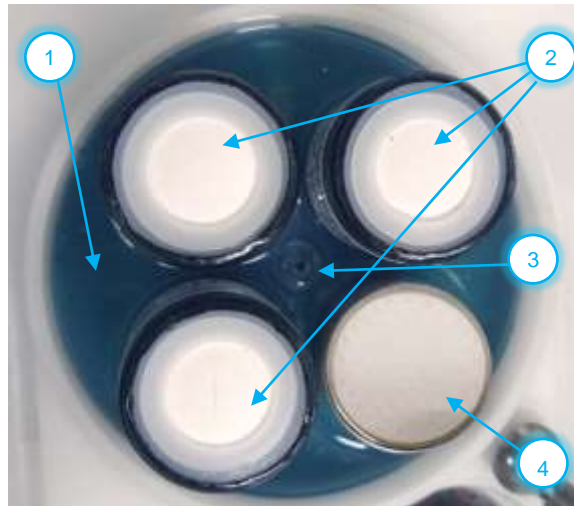

The Silicone Boot is there to prevent water accessing the connectors of the Sensors during a scrubber flood, or condensation etc. It should be properly seated.

It is good practice to ensure the Oxygen Sensors are fully dry after a dive. This may be accomplished by running gas over the Sensor Head using the Calibration Cover. First, before applying to the unit, connect the Sensor Cover to a source of dry gas (typically compressed air from a direct feed hose). Check to confirm that dry gas is emerging from the Calibration Cover (be cautious, for instance, when using gas from a bailout system that may have been depressurised during a dive). Without removing the Sensor Cover, place the Calibration Cover over the Sensor Cover and run dry gas over the sensors. 10 minutes should be sufficient to clear all condensation from the sensors. This also presents an opportunity to verify that the cells read correctly after the dive.

This practice ensures the Oxygen Sensors do not deteriorate in storage and allows any issues to be flagged and corrected before the unit's next use.

---

**.Warning:** **Do not expose the cells to liquid. If there is need to wash the surface of the sensor module, i.e. following a flood, do so with the sensors removed, and do not direct jets of water at the sensor head, especially the Pressure Sensor – use free flowing fresh water only.**

---



### 7.5.1.1. Analogue Output System - Care & Maintenance

To prolong lifespan, it is recommended that all cables and connectors are left assembled as far as possible and NOT disconnected after every dive but post dive cleaning procedure should be followed.

If you have a single analogue or A1 (see (1) in image below) or double analogue A2 upgrade, ((2) shows the Blanking Cap where the A2 upgrade would go) unscrew the Locking Sleeves (3), without disconnecting the cable or removing the blanking cap (4). Wash the Locking Sleeve and the metalwork in fresh water. Then leave to dry before reapplying the Locking Sleeve.

If it is desired to dive with the Orca v6 without using the Analogue Output(s) fitted, unscrew the sleeve, wash in fresh water, carefully disconnect the cable, and dry. Then lubricate and fit the Blanking Cap (male). Lubricate both it and the Bulkhead Connector with SGM494 silicone grease before reassembling.

Make sure to wash and dry all connectors before storage.



### 7.5.1.2. Replacing Oxygen Sensors

Make sure the Unit is switched off.

To replace oxygen sensors, remove the Sensor Cap, by gripping firmly and pulling upwards. The oxygen sensors are seated in a silicone boot and can be lifted out vertically between thumb and finger using light pulling force.



Remove the new cell from its packet, check the expiration date before inserting. If all cells are removed replace them in the order of 3, 2 and then 1. This is just to make sure the silicone boot does not become displaced.

To insert the sensor simply align the pins with the hole (one of the vent holes on the sensor match the position of the pins once they can no longer be seen) and push in gently. **If force is required, STOP: the sensor is misaligned. Remove the sensor, check the pin and socket alignment and start again.**

The gold-plated contacts maintain good connectivity and are held in place by the silicone boot. Make sure the silicone is sealed around the base of the sensor. This will help to prevent moisture entering the pins sockets.

Replace the Sensor Cap, check the O-ring for defects. Do not lubricate.

**Perform a calibration** as described above. It is best to wait at least half an hour after the cells are removed from their packaging to let them acclimatise.

#### **If you have the 4<sup>th</sup> O<sub>2</sub> cell option:**

Pull the old sensor out vertically (ensure that this is completely vertical). There may be a "pop" noise as the seal is broken. Retain the O-ring and the Support Ring.

Take your new sensor and add the blue support ring which has a flat edge and a curved edge. Put it on the base of the sensor, with the curved edge facing towards the pins (See below).

Push the sensor carefully into place (right). **If force is required, STOP: the sensor is misaligned. Remove the sensor, check the pin and socket alignment and start again.**

Taking the 4<sup>th</sup> sensor Install Tool (below), place it over the sensor and gently push the support ring down as far as it will go. Place the 4<sup>th</sup> Cell O-ring (BS019) around the cell.

The sensor is now set for calibration. If no reading is given, reset the sensor and try again.



Once you have reached the use-by date of the sensor, it must be removed and changed.

If changed, the 4<sup>th</sup> sensor must be calibrated.

#### 7.5.1.3. Disposal of old sensors

The O<sub>2</sub> sensors contain lead. They may be disposed of in the same facilities as used for recycling lead-acid batteries or returned to the manufacturer for performance analysis.

### 7.5.2. Handset Care

The Handset is not a user serviceable part. If there is a fault it should be returned to the Lungfish Dive Systems Ltd for repair or service. However, if damaged it can easily be swapped for another Handset, simply by unscrewing the locking sleeve and removing from the end of the cable. This can even be done underwater, though it is recommended to disconnect, wash the connectors in fresh water and dry afterwards!

The Handset Screen is recessed behind a protective Bezel (See (1) in the image below) and has a protective coating. It should be protected from scratches and knocks during diving and storage.

Do not clean the screen with any abrasive materials. Wash in fresh water and wipe with a soft microfiber cloth and a mild soap if necessary.

For periodic cleaning, without disconnecting the Handset Cable (2), from the Handset Bulkhead Connector (3) undo the Locking Sleeve (4) and rinse with fresh water and allow to dry and replace the locking sleeve before storage. Store the electronics with the Handset Cable in place.

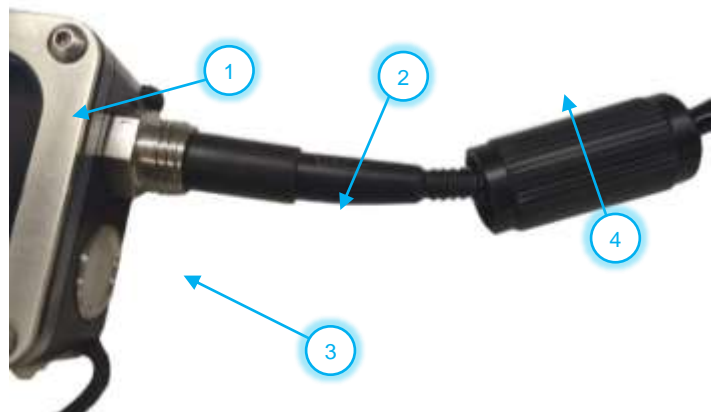

We recommend that the Handset is not disconnected without good reason. If it is disconnected, check the connections are free from debris and gently wipe any excess lubricant. For storage separately or for shipping the pins must be protected. We recommend a Blanking Cap (female) and Locking Sleeve be attached.

When reconnecting a cable or Blanking Cap to the pins apply SGM494 silicone grease, smearing this into the mating part before inserting the pins. Wipe away any excess grease once the connection has been fully made and secure with the Locking Sleeve.

The Handset should be stored in the case provided when not in use.

### 7.5.3. Medium Pressure Hoses & Cable Care and Replacement

It is recommended that cables are left connected when possible, and not disconnected between dives.

Do not bend the cables through extreme angles, especially near their connectors. Always wash and dry the connector before disconnecting a cable. This is good practice with the wet-mateable underwater connectors found on the Orca v6 Head and Handset, and vital with the dry-mate Fischer and other connectors used on the offboard cables.

---

**Warning:**

Never disconnect a Fischer or other dry-mate cable underwater, or without first washing in fresh water and drying. Dry and cap all exposed connections after disconnection to prevent the risk of corrosion.

---

All cables should be inspected visually before diving and after each week's diving. Look for permanent bends or kinks and bulges. Also check for cracks and fraying around any of the mouldings at the ends of the cables.

A damaged or non-functional cable can be replaced simply by unscrewing the locking sleeves, pulling the cable out and replacing with a new one.

Handset cables do not have a directionality (both ends are the same). Offboard cables have pins to match the sockets on the side of the Head, in a pattern that enables easy alignment.

Apply dielectric SGM494 silicone grease to the female part of a wet-mateable connector before reconnection. Proprietary Fischer oil should be applied to Fischer connectors. Use sufficient grease/oil to aid sealing, but not an excessive amount that will cause a hydraulic lock and inability to insert the connector.

Medium Pressure Hoses should be inspected frequently and replaced if damaged or every 5 years.

### 7.5.4. Storage

For long-term storage of the Electronics Module, be sure to pay attention to the warning below:

---

**Warning:**  Do not store the Electronics Module with a flat battery or allow the batteries to run down while in storage. Long term storage with a flat battery risks permanent battery damage. Additionally, the system's clock will lose its time and must be reset to the correct time using the Surface Software to ensure proper logging of dive times and dates.

---

To prevent this, fully charge the Electronics Module before storage, or make sure that the charge is checked monthly. If the batteries read less than 4 v on the handset, the Module should be recharged. If the Module is discharged sufficiently to drain the batteries completely, allow enough time (up to 8 hours with a 1 A charger) for it to be recharged before use, and remember to reset the clock. This scenario will show the "Date Error" alarm on the log.

---

**Warning:**  Under no circumstances should the white Hatch of the Electronics Head be opened. The electronics are not a user serviceable part and opening the hatch will void the warranty.

---

Additionally, it is important that the Electronics Module is stored in a dry condition. DO NOT put the Orca v6 unit into storage still assembled after diving. Remove the separate subsystems, clean and dry all parts of the electronics module as described above, and store in the waterproof case provided.

## 7.6. BCD and Harness care

The Wing Buoyancy Compensator Device (BCD) and Harness should provide years of reliable service. It is your task to care for them properly. Good preventative maintenance will extend their life. As the BCD cannot be removed from the Main Unit post-dive, the entire system should be washed together. See section on post-dive cleaning.

After dives and cleaning you should make sure your BCD has no water inside. With the electronics and scrubber canister removed, connect an air diluent gas source and inflate the BCD to cracking pressure. Then invert the harness and BCD so that the inflator hose is at the lowest point. With the inflator hose hanging downwards press the release button on the end so any water runs out of the hose. Wait until the water stops flowing. If you think water may still be trapped inside, reinflate and repeat until it is drained.

Do not press the inflate button while performing the drain operation as this may allow water to enter the low pressure inflation hose.

Protect your BCD from prolonged exposure to direct sunlight, extreme heat, and chlorinated water. You should keep the inner bladder from chafing against any sharp objects or rough surfaces, as well as avoid any contact with oil, gasoline, aerosols, or chemicals. Contact with these may damage the fabric or accelerate decay.

Dry your BCD and Harness in a cool, dry place. You can inflate the BCD slightly, and then hang it over a railing or a hanger. Be sure the BCD is completely dry before storing it.

### 7.6.1. Periodic care

After several days of diving:

Be sure to clean the interior of the BCD. Debris and salt crystals can make their way into the BCD when underwater through the venting of air. To clean the interior, push the Deflate Button while aiming the water from the hose into the mechanism. Once the water has entered the interior, shake the BCD a few times to spread it around. You can repeat this process several times. Drain as above.

Inspect your BCD and Harness for tears, ripped stitching, cracks, and any other problems. This will take only a few seconds but will help you to prepare for your next dive, especially if something needs to be fixed.

### **7.6.2. How To Store Your BCD & Harness**

#### **DO NOT:**

- Store the Unit in an enclosed space where it may be exposed to temperatures below -18 °C (0 °F) or above 49 °C (120 °F).
- Expose the BCD to direct sunlight, fumes, solvents, and chemicals.
- Spray silicone or other chemicals inside the BCD or on the oral inflator.

#### **DO:**

- Store the Unit in a cool, clean, dry place
- Partially inflate the Bladder to prevent the insides from sticking together.
- Remove all weight before storing.

## 8. Troubleshooting

---

### 8.1. Notes on sensor faults

#### 8.1.1. Oxygen Sensors

The Orca v6 uses highly robust Proprietary Oxygen Sensors (Part Number LF 0606031); however, these are fuel cells with a limited lifespan and **will eventually fail, and therefore should be replaced annually. Their replacement dates are printed on their labels. Oxygen Sensors are available from Lungfish Dive Systems or from an Authorised Dealer.** The system itself will ignore readings from any sensors that are shorted out, non-responsive, or otherwise obviously faulty, and will display such a situation to the user.

**To avoid suffering a sensor failure or warning during a dive, the following steps can be taken:**

- Never use sensors past their use-by date (printed on cell label).
- Life expectancy is 12 months.
- The accuracy of all oxygen sensors is affected by condensation on the faces. The Orca v6 system resists condensation build-up while it is switched on, but the Electronics Head should not be left switched off whilst installed on the Orca v6 after use.
- Post-dive, remove the Electronics Module, dry it and keep with "dry" kit, preferably in its original carry case – i.e., with your logbook and tool kit, not attached to the rebreather where condensation may form as the system cools, and not with the wet gear in the dive bag.
- If not practical to remove the Electronics between two consecutive dives, leave the system turned on.
- Calibrate before diving in both oxygen and in air (2-point calibration).
- Check the 3-sensor screen on the Handset.
- From time to time use the Calibration Cap to pressurise the sensors in pure oxygen. This should show up if the Sensors deviate or have become current-limited (expired life-time) and cannot read a sufficiently high PO<sub>2</sub>. Cells that are not linear up to the alarm level are unsuitable for use, while those that cannot even reach the setpoint are actively dangerous as they will drive ever-higher real oxygen levels while still reading low.
- The Calibration Cap may also be used to dry the Sensors by exposing them to a flow of dry gas.

It is good practice during the dive to see if the Sensors can detect, and agree on, a high PO<sub>2</sub> reading. Good times to do this are just after descent, when the oxygen levels will spike anyway, and during the last few metres of the ascent.

**An Oxygen Sensor failure that goes unnoticed has the potential to be a dangerous event during the dive, as it could cause the controller to deliver a fatally high PO<sub>2</sub>.**

#### 8.1.2. Depth Sensor:



Depth Sensor failure and Sensor Head failure underwater are highly unlikely circumstances unless the Orca v6 suffers either physical damage, serious flooding of the electronics compartment or incorrect disassembly/reassembly.

The **Depth Sensor** is a sensitive piece of equipment, and it is important:

- NOT TO RISK PHYSICAL DAMAGE. (If it is necessary to clean, i.e., after a flood, DO NOT do this with any kind of probe or air-jet.)
- If you must clean the Sensor Head (for instance, if you have dropped it in the sea or grossly flooded the Unit), use fresh de-ionised water only and **do not touch the Depth Sensor**.
- The Depth Sensor readings are affected by UV radiation, so erroneous readings may be shown if it is directly exposed to bright sunlight. This is transient and causes no damage.

---

**Warning: The Depth Sensor cannot be repaired, only replaced at the factory. Avoid damage.**



---

### 8.1.3. Carbon Dioxide Sensor:

Gross damage to the CO<sub>2</sub> Sensor will result it being deactivated by the system and an appropriate error message on the screen. Do not dive.

In case of a flooding, the Sensor fails high. A sufficient flood to cause this underwater requires the same response as a real CO<sub>2</sub> alarm: Bail Out. A persistent, high but fluctuating reading that does not decrease even in air or pure oxygen indicates a wet sensor that is shorting out. Turn off the Unit and remove the O<sub>2</sub> and CO<sub>2</sub> sensors immediately.

This being done, remove the Sensor Boot from the Sensor Head.

---

**Warning: Extreme care must be taken to avoid touching the Depth Sensor.**



---

Then thoroughly rinse the sensor bases and the sensor head face itself in fresh, preferably distilled or de-ionised water, making sure you flush the connector sockets and let any bubbles escape, and allow all parts to dry thoroughly before reassembly. The corner of a tissue may be used to remove water from the sensor sockets. The CO<sub>2</sub> sensor itself may be rinsed in water but must be thoroughly dried to avoid corrosion.

Replace the Sensor Boot and the CO<sub>2</sub> and Oxygen Sensors.

Calibrate the Oxygen Sensors as above, verifying the CO<sub>2</sub> Sensor reads zero % in 100% Oxygen. Test responsiveness of the CO<sub>2</sub> Sensor by breathing gently on it and noting a change in the reading.

---

**Warning:** If the CO<sub>2</sub> sensor is not responding in any way, contact your Orca v6 service technician.



---

The low-end accuracy of the sensor (in fractions of %) is reduced by condensation. This may occur if the Unit is allowed to cool with the electronics installed while turned off. The effect is transient. The same points apply as with the oxygen sensors: avoid leaving the head turned off in the Orca v6 after diving. The sensors may also be rid of condensation using the Calibration Cap to dry them.

## 8.2. Pressure checks

Major leaks usually indicate any of the following:

- Mis-assembly or not having connected a component.
- Broken, pinched or omitted O-rings.
- Dirt or debris holding the OPDV open (listening for the source of the leakage will locate it).

Minor leaks (not detectable by listening; slow change in volume) might stem from loose connections or minor damage to counterlungs or seals.

Any damage to counterlungs require them to be returned to a service centre, they are not a user serviceable part. Damaged O-rings should be replaced.

The Push Fit Connector for the ADV and the base of the OPDV can be tightened by hand, or with specific tooling supplied by Lungfish (do not overtighten the cap of the OPDV) and gas fittings carefully tightened with a spanner.

Leaking MAVs or ADV can be identified by directing their outlets into water. Bubbles will indicate a leak.

Immersion of the Unit in water (in a basin) will allow these to be pinpointed.

## 9. Technical Specifications

### Expected inspired gas concentrations:

This table corresponds to use of the automatic setpoint, including variable PO<sub>2</sub> at the depths specified. The specified PO<sub>2</sub> alarm levels are between 0.5 and 1.55 bar.

To exceed a depth of 40 m, a trimix diluent must be used. Use of trimix and diving beyond 40 m requires additional specialist training.

Depth	Absolute pressure (bar)	Setpoints Auto (bar)	PO <sub>2</sub>	Fraction O <sub>2</sub>	PN <sub>2</sub>	Fraction N <sub>2</sub>
0 m-At surface	1.00	0.60	0.60	60%	0.40	40%
3 m	1.30	0.78	0.78	60%	0.52	40%
6 m	1.60	0.98	0.98	60%	0.64	40%
10 m	2.00	1.20	1.20	60%	0.80	40%
20 m	3.00	1.20	1.20	40%	1.80	60%
30 m	4.00	1.20	1.20	30%	2.80	70%
40 m	5.00	1.20	1.20	24%	3.80	76%
50 m	6.00	1.20	1.20	20%	4.80	80%

**High pressure system:** The Orca v6 is supplied 200 bar oxygen and diluent 1<sup>st</sup> stage regulators. 200 bar cylinders designed specifically to fit the Unit are available.

**Low pressure system:** The low pressure system supplies gas from the 1<sup>st</sup> stage regulators at 6-8 bar. The rated pressure for the BCD is 6 to 11 bar.

**Breathing performance:** Using the standard breathing loop at 40 m with air diluent, with a tidal volume of 3 litres and a breathing rate of 20 bpm, the work of breathing is 1.33 joules per litre. With a tidal volume of 3 litres and a breathing rate of 25 bpm, the work of breathing is 1.72 joules per litre.

**Safety Devices:** The Orca v6 has an integrated BCD that provides 110 N of lift for effective buoyancy control. The pneumatics system may optionally be connected to a drysuit.

The Orca v6 and the BCD are secured to the diver with a 5-point harness to ensure the diver does not become separated from the Unit. When fitted correctly this does not affect the diver's ability to swim in normal conditions and allow them to return to the surface. The Electronics Head and Handset contain both visual and audible alarms of sufficient brightness and sound level to alert the diver to potential hazards. Poor visibility in the water will increase risk.

Under normal operating conditions the Grids and Fabric Mesh Disks should prevent dust from scrubber material from affecting the diver. In the case of a flooded unit the diver may risk exposure to caustic substances and should bail out in this circumstance.

### 9.1. Limitations on use.

**Gas mixtures:** Maximum recommended depths for breathing:

Air diluent should be used to a maximum depth of 40 m (1.2 bar oxygen, 3.8 bar nitrogen).

Trimix diluent should be used to a maximum depth of 100 m with Trimix 10/70 (1.2 bar oxygen, 2.18 bar nitrogen, 7.62 bar helium).

**Gas Purities:** (All gases used need to meet EN 12021)

Oxygen: ≥99.5% (Diving Grade Oxygen)

Air: EN 12021

Helium: ≥99.99 (4.0 grade)

**Gas Duration:** Gas duration depends on the size of the cylinders used.

If Lungfish Dive Systems 2 l 200 bar cylinders are used, at a nominal consumption of 1.78 l/min, rounded to 2 l/min to err on the side of caution, and allowing for a reserve of 50 bar as specified under EN 14143, the gas endurance rated as 150 minutes.

Diluent supply duration depends on the dive profile.

**Scrubber Duration:** Based on testing according to EN 14143:2013, scrubber duration of the standard unit is rated as follows:

- 40 m: 130 min  
(2.3 kgs Sofnolime 797 1-2.5 mm, 0.5% SEV CO<sub>2</sub>, water temp 4 °C, CO<sub>2</sub> production 1.6 l/min, air diluent)
- 100m: 130 min  
(2.3 kgs Sofnolime 797 1-2.5 mm, 0.5% SEV CO<sub>2</sub>, water temp 4 °C, CO<sub>2</sub> production 1.6 l/min, diluent Trimix 10/70)

**Depth:** The equipment is designed and certified for use to a depth of 100 m.

**Water temperature:** The Orca v6 must not be used in water below 4 °C or above 34 °C

**Visibility:** If visibility is less than 30 cm you should consider aborting the dive. While you may be able to see your handset you may not be able to see an alarm on your buddy's that they have not noticed and vice versa.

**Use by Colourblind People:** This has been dealt with by the OK and "!" signs on the handset, as well as the flash/ steady pattern and the choice of colours for the partially colourblind (OK light is always greener than screen, Alert is always redder) and the left-right positional arrangement. Users are never left to rely on lights alone due to the messages. An audible alarm is also included.

**Buoyancy Compensator Device:** The BCD is not a life jacket or a rescue device. The BCD should not be used as a source of breathable gas. Only to be used as part of this rebreather.

**Inflator:** Supply pressure minimum : 6 bar, maximum 17.23 bar (250 PSI). Water temperature minimum -2 °C, maximum 40 °C

**BCD Cylinder Parameters:** 2 x 11 l plus onboard 2 x 2 l

**Compatible Accessories:** The Orca v6 has been tested with the electronics and hardware presented in the Components section of this manual.

## 9.2. Health Effects

**General:** At the time of writing there are no long-term studies on the effects of rebreather use, however the diver should be aware of the effects of CNS O<sub>2</sub> toxicity, pulmonary O<sub>2</sub> toxicity, acute and long-term effects of decompression, carbon dioxide toxicity, pulmonary oedema, and the risk of inhalation of caustic liquids. Avoidance of these issues should be covered during training.

**Use of high oxygen content gases:** Central Nervous System (CNS) Toxicity and Pulmonary Toxicity are known risks of diving that must be avoided by rigorous adherence to procedures and not exceeding safe exposure limits.

- To protect against acute CNS toxicity and the risk of a seizure underwater, the Orca v6 high setpoint is set at 1.2 bar as standard, inside known safe limits, with an alarm triggered at 1.55 bar, should the PO<sub>2</sub> reach this point through manual addition, rapid descent or malfunction. Nonetheless rigorous training is required to respond appropriately to such scenarios.
- To protect against chronic / pulmonary toxicity, the diver must themselves keep track of their Oxygen Toxicity Units, defined as one unit per one minute of breathing 1 bar of O<sub>2</sub>, with 300 OTUs being a conservative limit for multi-day diving. This again is covered in the training necessary to use a rebreather.

## 9.3. BCD warning label

**General:** Follow all warnings printed on the label attached to the BCD.



**Warning:**  
THIS IS NOT A LIFE JACKET OR A RESCUE DEVICE.

IT DOES NOT GUARANTEE A HEAD UP POSITION OF THE WEARER AT THE SURFACE

IMPORTANT NOTICE: THIS EQUIPMENT SHOULD ONLY BE USED AFTER PROPER TRAINING ON THE USE OF BUOYANCY CONTROL DEVICES HAS BEEN COMPLETED. IT HAS BEEN DESIGNED TO CONTROL YOUR BUOYANCY WHEN IT IS NEGATIVE OR POSITIVE TO MAKE YOUR DIVE EASIER AND SAFER.



**Caution:**  
CARE AND MAINTAINANCE (See user instructions)

- 1) With the BCD still inflated, drain any water into the side of the BCD with the OPDV. Orientate the Harness and BCD so that the BCD OPDV is at the lowest point and drain and water from the BCD. Repeat as necessary to empty the BCD bladder.
- 2) Always wash the BCD, including the inside of the bladder, in fresh water after every dive. Diving in chemically treated swimming pools could damage or discolour the fabric of the BCD.
- 3) Place to dry out of direct sunlight in a well-ventilated place. Do not leave on the ground for extended periods of time.

**ORCA v6 Serial No:**

**ORCA v6 BCD Serial No:**

Max Cyl. Combination  **BUC**

2 x 2 l + 2 x 11 l

Onboard    Offboard

Buoyancy 110 N



LDS, New Cambis House,  
Litlington, SG8 0SS, U.K.

EN 1809:2014+A1:2016  
EN 14143:2013

 **Warning:**

As Personal Protective Equipment (PPE), before diving an ECCR it is essential that you receive specialist training. Failure to do so could lead to serious injury or death.

If water enters the breathing loop there is a risk of ingesting caustic liquid.

The ORCA v6 is rated to 100m. The maximum depth of the apparatus depends on the gas mixture used.

Cold water rated, 4 degrees centigrade.  
Maximum water temperature for diving is 34 degrees centigrade

Serial No:

**ORCA v6**  
**EN 14143:2013**

 **CE** **UK** **CA**  
0120  
LDS, New Cambs House,  
Utlington, SG8 0SS, U.K.

# 10. Preparation Checklist

## ELECTRONICS

<b>OXYGEN CELLS</b>	<b>1</b>	<b>2</b>	<b>3</b>	<b>4 (opt)</b>
EXPIRATION DATE				
CALIBRATION DATE				
mV IN OXYGEN				
mV IN AIR				
DIVE COMPUTER(S) calibrated - indicate which cells				

MAIN UNIT BATTERY (disconnect charger, 3.9v min advised)	Voltage		Endurance	
SOLENOID BATTERY (disconnect charger, 3.9v min advised)	Voltage		Endurance	

CONFIRM NO FAULTS OR SYSTEM ALARMS	Main Unit		Computer	
CONFIRM ALL CONNECTIONS FITTED OR CAPPED	Charge port		Cables	

## SCRUBBER

CONFIRM FILLED WITHIN 24H (DATE)	
MATERIAL TYPE / USE-BY DATE	
CORRECTLY FILLED / NO NOISE WHEN SHAKEN	

## GASES

GAS	O <sub>2</sub> %	He%	N <sub>2</sub> %	Volume	Pressure	MOD	Leaks?	Programmed?
ONBOARD O <sub>2</sub>								
ONBOARD DILUENT								
BAILOUT 1								
BAILOUT 2								
BAILOUT 3								
Intended Dive Depth and Duration								



**PNEUMATICS**

O2 and DILUENT GAUGES FUNCTIONAL			
AUTOMATIC DILUENT VALVE FUNCTIONAL			
O <sub>2</sub> BYPASS / MANUAL ADD VALVE FUNCTIONAL	Action	QD	
DILUENT BYPASS / MANUAL ADD VALVE FUNCTIONAL	Action	QD	
BCD FUNCTIONAL / NO LEAKS			
BAILOUTS FUNCTIONAL / NO LEAKS	1	2	3

**LOOP**

INHALE COUNTERLUNG – NO LEAKS				
EXHALE COUNTERLUNG – NO LEAKS				
BREATHING HOSES – NO LEAKS				
BREATHING HOSES - DIRECTIONALITY				
POSITIVE CHECK		DURATION		DUMP – gas out
NEGATIVE CHECK		DURATION		DUMP – no gas in
LUNGS SIZED TO MATCH USER				

**BCD**

CYLINDER BANDS – NOT WORN. VELCRO OK. CLAMP OK.	
WEBBING / D-RINGS / BUCKLES / CROTCH STRAP – NOT CRACKED OR FRAYED	
BCD FABRIC – NO FRAYING OR HOLES	
INFLATOR / DEFLATOR – OPERATES SMOOTHLY	
DUMP VALVE – OPERATES SMOOTHLY	
DUMP CORD – NOT TANGLES. PULLS FREELY	
HOLDS PRESSURE	